



## SWM 4111 Series

### Full Installation Guide

Everything you need to get your Era 100 mounted, in no time

#### Before you start

...we just wanted to say thanks for choosing Vogel's. Smart choice.

And you're already making another smart choice – reading the manual! Keep reading to learn all about safe, efficient installation, and how to use your new mount.

---

#### Stay safe



##### Warning

Always read these safety instructions carefully before installing and using this product.

Following these instructions is strictly required. Incorrect mounting and/or installation could put you, your speaker, and your family at substantial risk.

Don't dare risk it... Read all

- Vogel's recommends that the mounting and/or installation of this product should be carried out by a suitably qualified expert.
- Vogel's cannot be held responsible for any injury and/or damage caused by incorrect installation.
- The wall mounting accessories provided are exclusively intended for installation on walls made of solid brick, solid concrete or solid wood columns.
- Any material covering the wall must not exceed 3 mm/ 0.12 inch.
- For mounting on walls made of other materials, such as hollow bricks, wood panels or plasterboard, please consult your installer and/or specialist supplier.
- Please be advised that this wall mount is exclusively designed for the use with the Sonos Era 100 speaker model. Utilizing this stand with other models or brands could potentially result in instability, malfunction, or damage to your equipment, and may also pose a safety risk.
- Clean the product with a dry, lint-free cloth. Do not use detergents or other solvents to clean the product.
- Only qualified, certified personnel may repair the product. Use only original spare parts. The use of other parts will result in voiding the warranty, and could lead to injuries.
- Alterations to the product and technical modifications are not permitted. This will void the warranty, and could lead to injuries.
- Always store the product in a dry and safe place with a temperature between -10°C to +50°C.
- Handle and transport the product with care.
- Repack the product when transporting or not using it for a longer period of time.

## What's in your box?

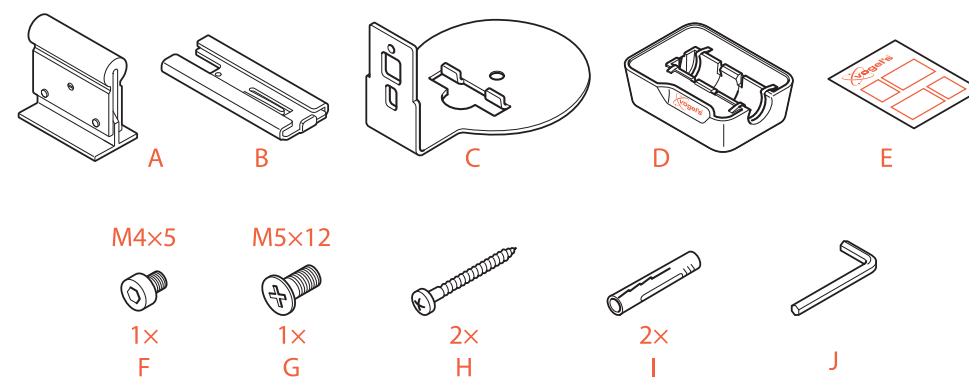

- Something missing? Make sure your packaging has everything in place:
  - A. Tilt module
  - B. Tilt bracket
  - C. Speaker bracket
  - D. Wall mount
  - E. Quick installation manual
  - F. 1x M4\*5mm bolt
  - G. 1x M5\*12mm bolt
  - H. 2x wall screws
  - I. Fischer® Plugs
  - J. No.3 Allen key

## Got your tools ready?

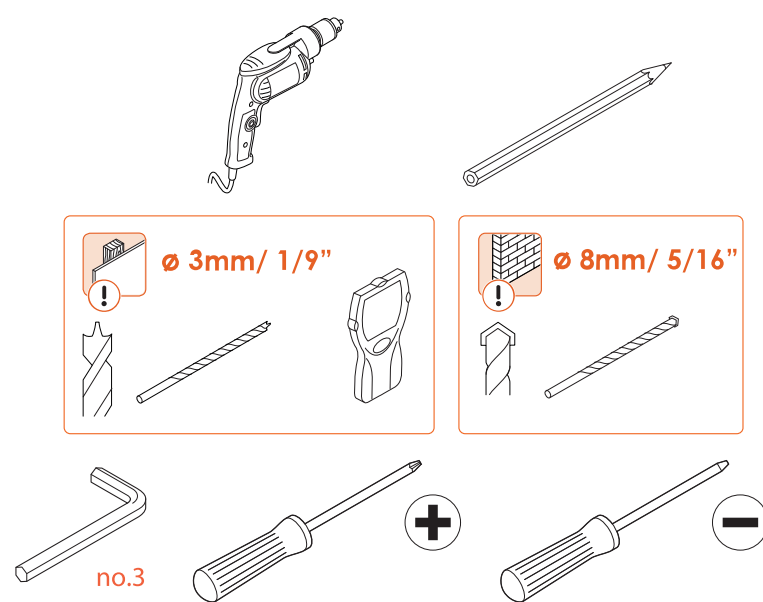

- Don't start without all the necessary tools:

- Drilling machine
- Pencil
- For walls with wooden studs: 3mm or 1/9" wood drill
- For walls with wooden studs: Stud finder
- For concrete/brick walls: 8mm or 5/16" concrete/brick drill
- No.3 Allen key (provided)
- Crosshead screwdriver
- Flathead screwdriver

## Take care of your safety

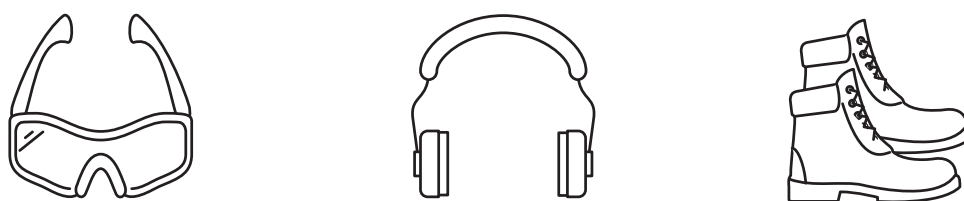

- Who cares about looking cool? Always wear personal protective equipment:

- Eye protection
- Ear protection
- Safety shoes

## Ready... set... get installing!

### Step 1: Assemble the speaker mount

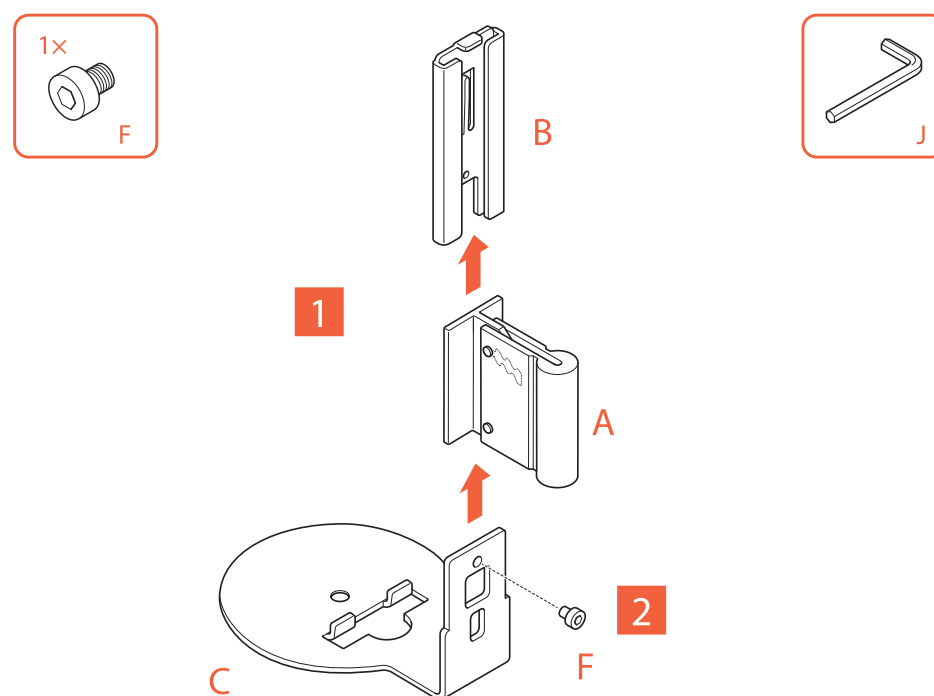

1. Slide the **tilt module** Ⓐ and the **speaker bracket** Ⓒ in the **tilt bracket** Ⓑ.
2. Attach the **speaker bracket** Ⓒ, the **tilt module** Ⓐ and the **tilt bracket** Ⓑ to each other by screwing the **1x M4\*5mm bolt** Ⓕ into the **speaker bracket** Ⓒ.

## Step 2: Attach the Era 100 to the speaker bracket

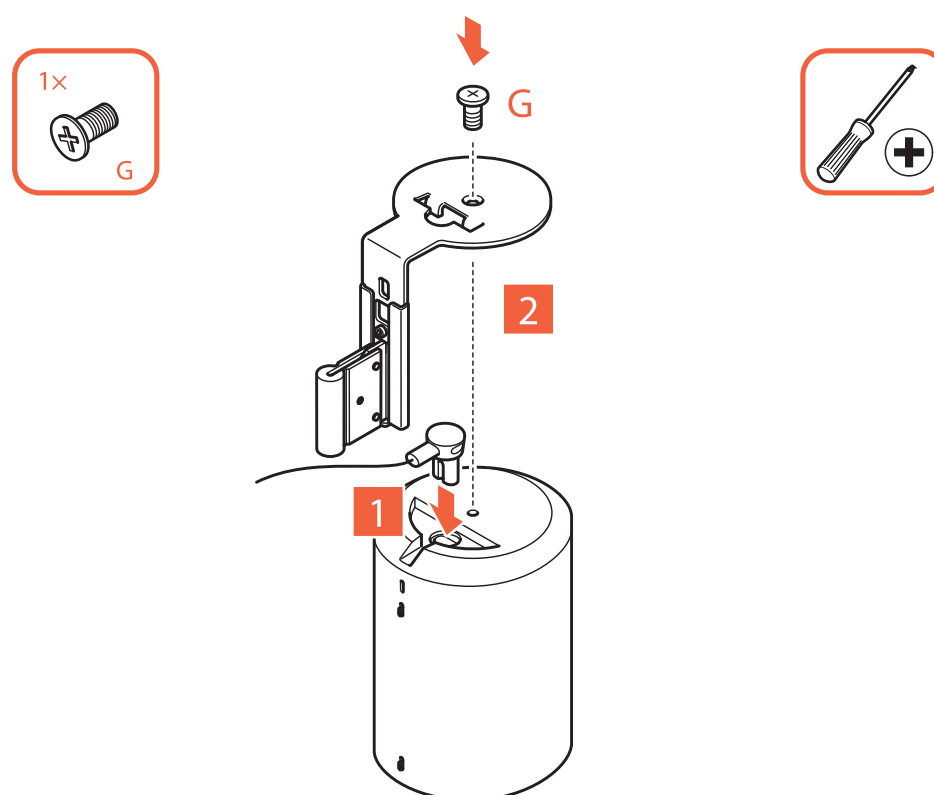

1. Connect the plug to the speaker (not provided).
2. Attach the speaker to the **speaker bracket** Ⓒ using the **1x M5\*12mm** Ⓖ.

## Step 3: Attach the wall mount to the wall



Your speaker can be mounted upside down, consider this when deciding where you want to mount your speaker and where its controls will be.

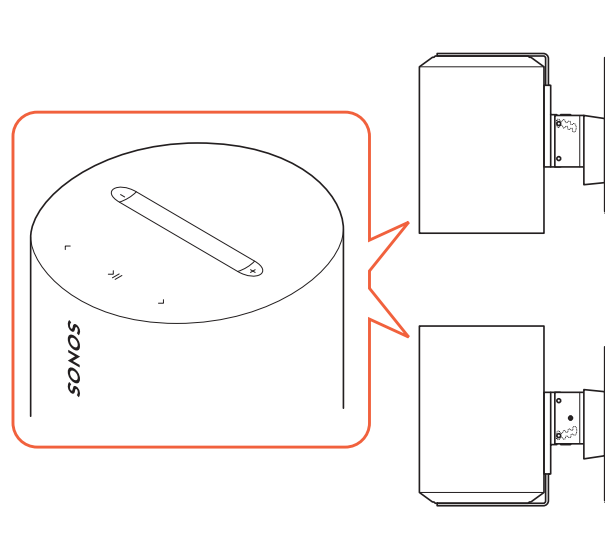

How well do you know your walls? What they're made of matters more than you think...

### Concrete / Brick wall

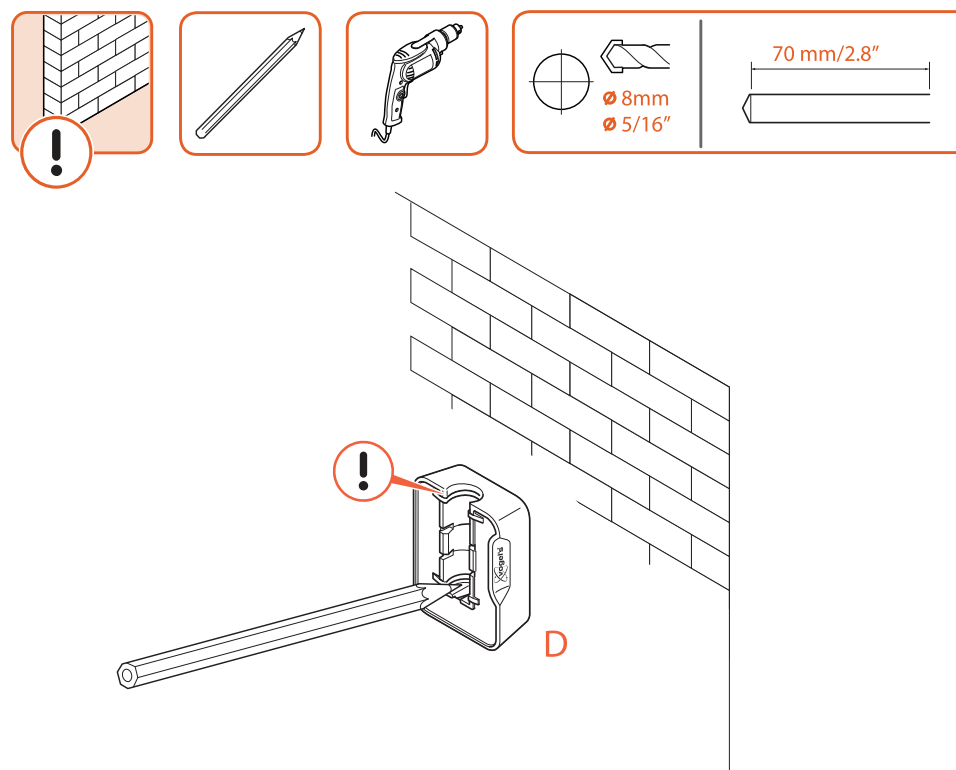

1. Decide how high you want the speaker to be.
2. Hold the **wall mount** © against the wall and mark the location of the 2 holes.



How deep do you drill? Check the length of the screw (not the plug!) to find the right depth – this stops things from breaking.

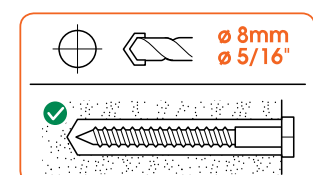

3. Mark the drill at the length of the **screw** ⊕.
4. Drill until the thread of the **screws** ⊕ completely fits in the holes.



Do not use the wall mount as a drill guide.



Up for some smooth sailing? Pre-drill the holes with a 5mm concrete/brick drill.

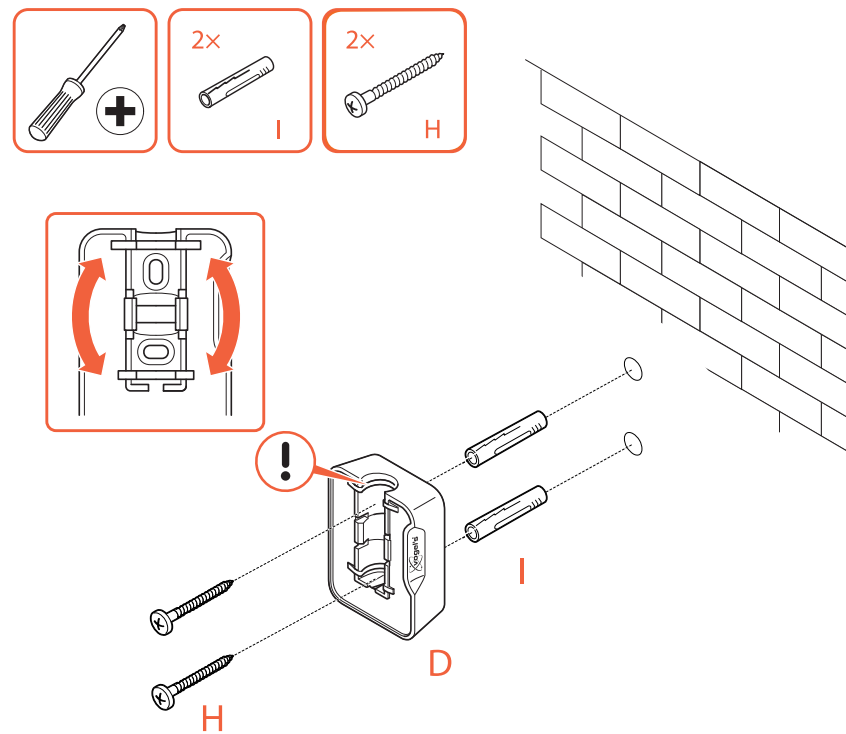

5. Attach the **wall mount** ④ to the wall with the **screws** ⑤, and **plugs** ⑥. Use the integrated spirit level to tilt the **wall mount** ④ until it is level.



Make sure the wall mount is mounted with the opening pointing towards the ceiling.



Lubricate the screws for easy screwing in.

Walls with wooden studs

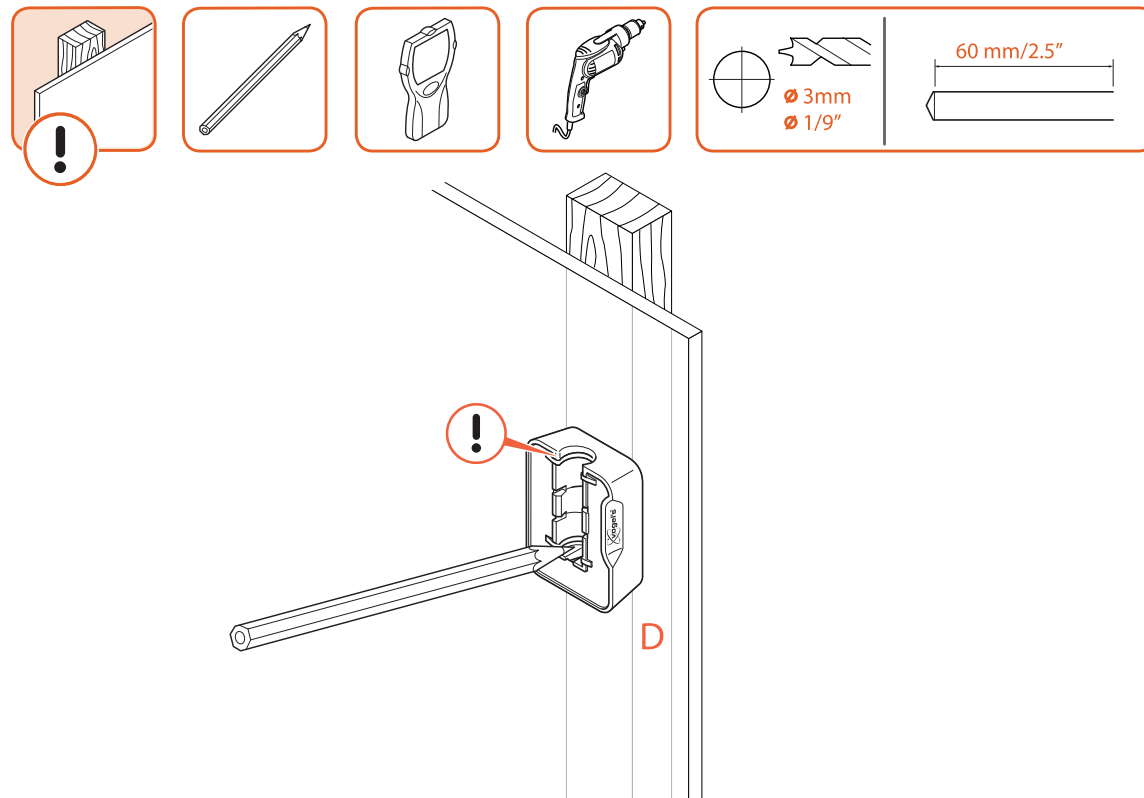

1. Don't just guess! Always use a stud finder to determine the position of studs.
2. Decide how high you want the **wall mount** ① to be.
3. Hold the **wall mount** ① against the wall and mark the location of the 2 holes.
4. Mark the drill at the right length.
5. Now for the fun part... drilling the holes.



Do not use the wall mount as a drill guide.

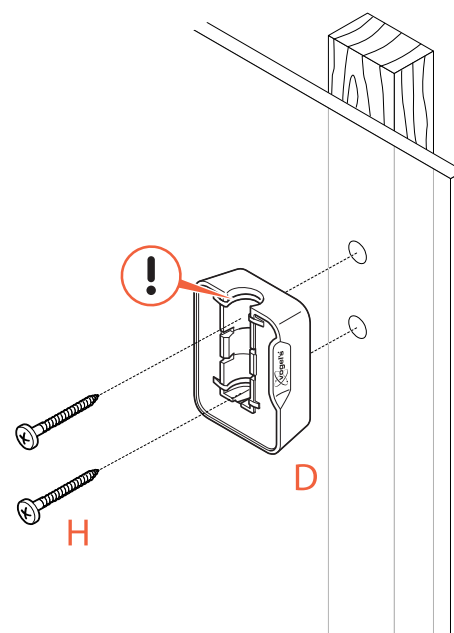
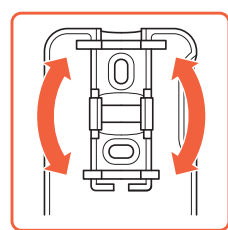
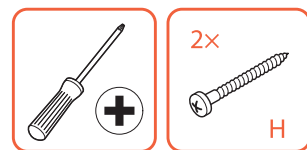

6. Attach the **wall mount** ① to the wall with the **screws** ②. Use the integrated spirit level to tilt the **wall mount** ① until it is level.



Make sure the wall mount is mounted with the opening pointing towards the ceiling.



Lubricate the screws for easy screwing in.

Other wall type / I don't know my wall type



If your wall is a little special – for example, hollow bricks, metal stud walls, wood panels or plasterboard – or you simply aren't sure, don't worry! Just ask your installer, specialist supplier or the Vogel's Consumer Care team at [www.vogels.com/contact](http://www.vogels.com/contact) (<http://www.vogels.com/contact>).

## Step 4: Attach the Era 100 to the wall mount

Right side up mounting

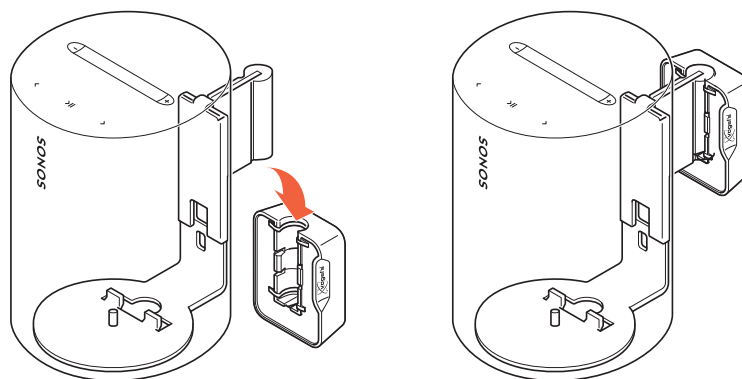

1. Lift the speaker and put the **tilt module** ④ in the **wall mount** ⑤.



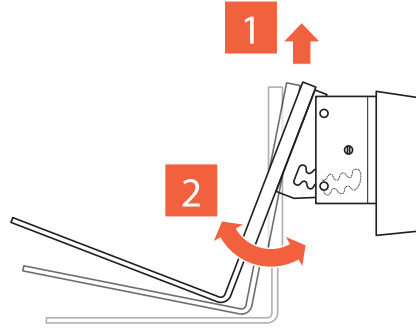

2. Slightly lift and tilt the speaker to your desired angle.

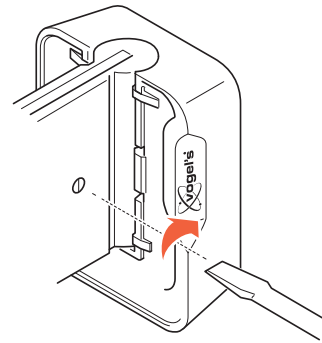

3. Fasten the speaker by tightening the setscrew on the side of the **tilt module** ④.

### Upside down mounting

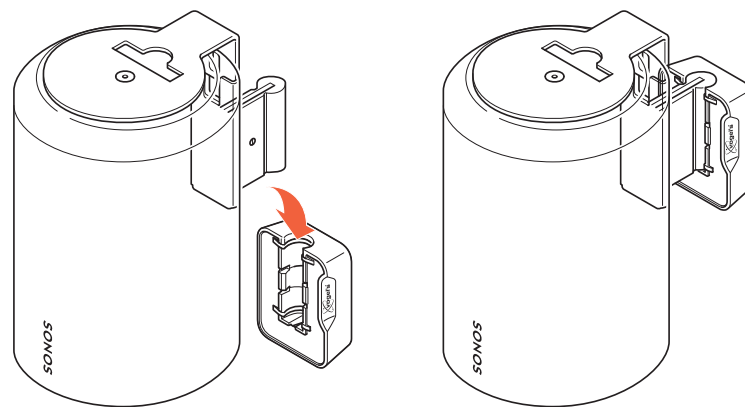

1. Lift the speaker and put the **tilt module** ④ in the **wall mount** ③.

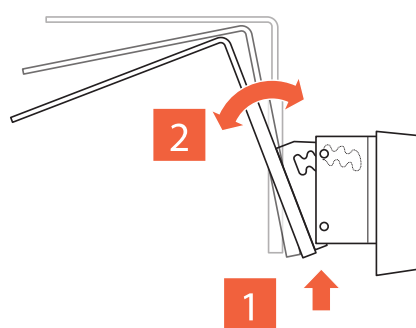

2. Slightly lift and tilt the speaker to your desired angle.

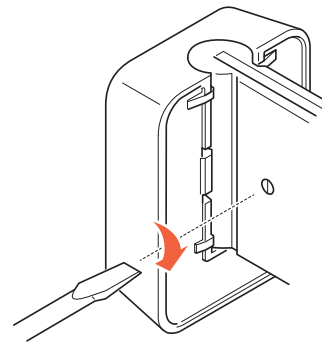
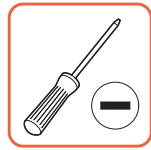

3. Fasten the speaker by tightening the setscrew on the side of the **tilt module** ④.

Job done now! Enjoy listening to your speaker!



Having a cable mess? Do you need inspiration about how to hide and guide your cables? Take a look at our website [vogels.com](https://www.vogels.com/) (<https://www.vogels.com/>)!

## Removing your speaker



1

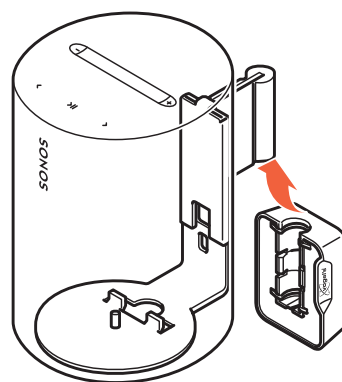

2

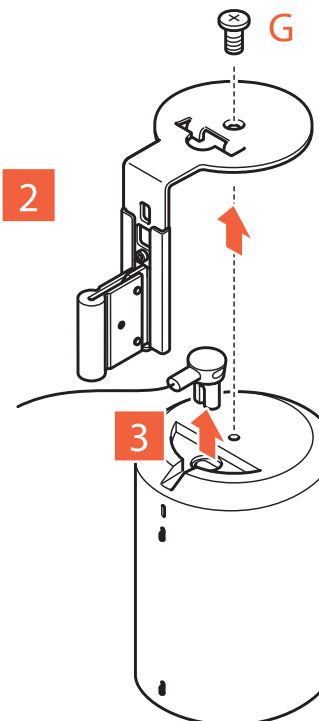

3

1. Lift the speaker out of the **wall mount** ④.

2. Unscrew the **1x M5\*12mm** ④ from the **speaker bracket** ④ to remove the speaker.

3. Disconnect the plug from the Era speaker.

Confused? Unsure? Going crazy?

There's plenty of help waiting for you, online:



[info@vogels.com](mailto:info@vogels.com) (<mailto:info@vogels.com>)  
[www.vogels.com/contact](http://www.vogels.com/contact) (<http://www.vogels.com/contact>)



[facebook.com/VogelsForSure/](https://www.facebook.com/VogelsForSure/) (<https://www.facebook.com/VogelsForSure/>)



[instagram.com/vogels\\_official/](https://www.instagram.com/vogels_official/) ([https://www.instagram.com/vogels\\_official/](https://www.instagram.com/vogels_official/))



[www.youtube.com/c/VogelsForSure](https://www.youtube.com/c/VogelsForSure) (<https://www.youtube.com/c/VogelsForSure>)

## Simple troubleshooting

Found a problem you can't fix? Don't panic... try these!

Problem	Cause	Solution
'My wall screws have snapped!'	You might not be drilling deep enough... or your drill could be too blunt, so that the hole is too narrow and the screw gets stuck.	Use another hole in the wall plate to fix the wall mount to the wall. Make sure you use a sharp drill of the correct size. Use the size of the screw as indication of the depth to be drilled. After drilling, check if the entire screw (except the head) fits in the hole.

## Go green!

We care about the planet. If you're getting rid of the packaging or the wall mount itself, please visit your local recycling facility, or contact your municipal office. On <https://www.vogels.com/recycle> (<https://www.vogels.com/recycle>) you can find information on the materials used in the packaging for swift sorting. Recycling matters!



## Guarantee



Thanks again for choosing Vogel's! Durability is paramount in the development and production of our products. We provide a guarantee of 5 years, unless local statutory law and regulation dictate a longer minimum period. We resolve any issues regarding product complaints or returned products and assess all complaints based on usage.

If your product is not functioning properly due to material faults or manufacturing defects, we will repair it free of charge or replace it at our own discretion.

If you have any problems with our product or want to know whether the guarantee is applicable, please:

1. Complete the contact form or mail our Consumer Care Team. Preferably, please add a picture.
2. Within 2 business days you will be contacted by our local Vogel's distributor.
3. If the guarantee is invoked, the product should be returned, together with the original purchase document (invoice, sales slip or cash receipt). The purchase document should clearly show the name of the supplier and the date of purchase. You will be informed about the specific return address and further procedure.

Vogel's guarantee shall lapse in the following cases:

- If the product has not been installed or used in accordance with the instructions;
- If applicable, if the holes in the wall have not been properly drilled in accordance with the Vogel's installation instructions for the applicable wall type;
- If the product has been altered or repaired by someone other than Vogel's;
- If a fault arises due to external causes (outside the product) such as for example lightning, water nuisance, fire, scuffing, exposure to extreme temperatures, weather conditions, solvents or acids, wrong use or negligence;
- If the product is used for different equipment than is mentioned on or in the packaging.

Do you have any other questions? Please make use of our contact form.

---

Vogel's Products BV - Hondsruglaan 93 - 5628 DB Eindhoven - The Netherlands

Vogel's Products BV 2023 © All rights reserved.