

Flat display interface PFI 3020



Specifications

- Max. weight: 30 kg / 66 lbs
- Guarantee: 5 years
- Available colours: Black

The PFI 3020 display interface is a part of the modular Connect-it system with which you can create your own ceiling solution for small- to medium-sized displays.



Flat display interface PFI 3020

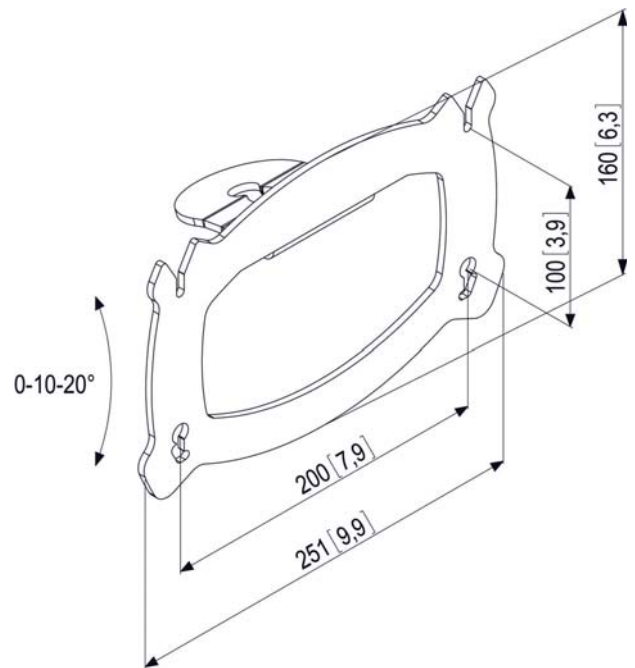

The PFI 3020 is suitable for small- to medium-sized displays (VESA 200x100 mm) up to 30 kg. This interface is equipped with a levelling and tilting function (incremental 0-10-20°). Combine this display interface with one of the Connect-it ceiling plates (PUC 1010, PUC 1030 or PUC 1040) or the truss adapter (PUC 1050) and one of the poles from the Connect-it Series (PUC 2108, PUC 2115, PUC 2130, PUC 2308, PUC 2315 or PUC 2330) for a complete ceiling solution.

Features

- 0-10-20° tilt function
- Levelling function
- Fits on PUC 21xx and PUC 23xx poles

Logistic information

- Packaging size: 160x262x149 mm
- Max. weight: 1 kg / 2 lbs
- EAN Code: 8712285317286