



Truss adapter
PUC 1090

Specifications

- Max. weight: 80 kg / 176 lbs
- Guarantee: 5 years

The PUC 1090 truss adapter is part of the modular Connect-it system with which you can create a truss solution for medium- to large-sized displays.

Truss adapter PUC 1090

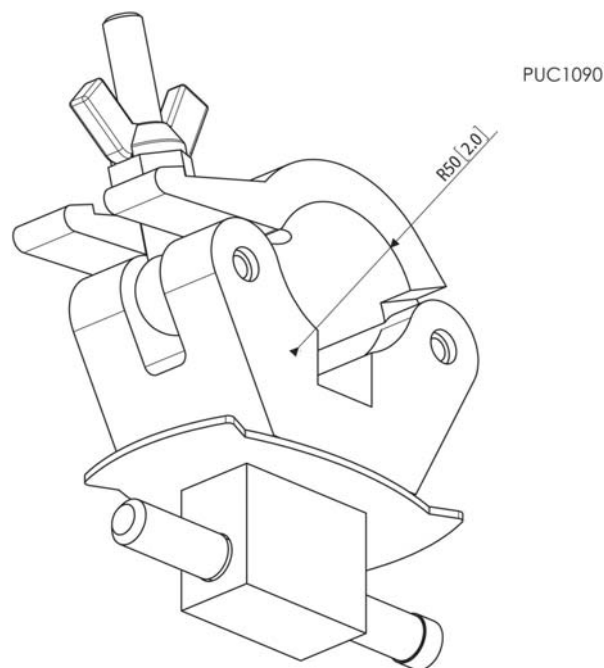

This truss adapter is suitable for 51 mm truss systems. Combine this truss adapter with one of the poles from the Connect-it Series (PUC 2508/ 2515/ 2530), Connect-it interface bar (PFB 3405/ 3407/ 3409/ 3411) and Connect-it interface display strips (PFS 3303/ 3304/ 3305/ 3306/ 3308/ 3311) for a complete ceiling solution.

Features

- Truss adapter for 51 mm truss systems
- Max. load: (2x) 80 kg / (2x) 176 lbs

Logistic information

- Packaging size: 136x158x69 mm
- Max. weight: 1 kg / 2 lbs
- EAN Code: 8712285319389