



Full Installation Guide

Everything you need to get your TV safely on the wall, in no time

Before you start

...we just wanted to say thanks for choosing Vogel's. Smart choice.

And you're already making another smart choice – reading the manual! Keep reading to learn all about safe, efficient installation, and how to use your new mount.

Stay safe



Warning

Always read these safety instructions carefully before installing and using this product.

Following these instructions is strictly required. Incorrect mounting and/or installation could put you, your TV, and your family at substantial risk.

Don't dare risk it... Read all

- Vogel's recommends that the mounting and/or installation of this product should be carried out by a suitably qualified expert.
- Vogel's cannot be held responsible for any injury and/or damage caused by incorrect installation.
- Please consult the manual for your TV and ensure that the weight and size of the TV is within the maximum weight and size limits specified for this product, and that the TV mounting bolts used are of a suitable length and diameter. Note that not all the TV mounting accessories provided are required for the installation of any one TV.
- The wall mounting accessories provided are exclusively intended for installation on walls made of solid brick, solid concrete or solid wood columns.
- Any material covering the wall must not exceed 3 mm/ 0.12 inch.
- For mounting on walls made of other materials, such as hollow bricks, wood panels or plasterboard, please consult your installer and/or specialist supplier.
- Clean the product with a dry, lint-free cloth. Do not use detergents or other solvents to clean the product.
- Only qualified, certified personnel may repair the product. Use only original spare parts. The use of other parts will result in voiding the warranty, and could lead to injuries.
- Alterations to the product and technical modifications are not permitted. This will void the warranty, and could lead to injuries.
- Always store the product in a dry and safe place with a temperature between -10°C to +50°C.
- Handle and transport the product with care.
- Repack the product when transporting or not using it for a longer period of time.
- Lifting your TV is a two-person job. Don't be bold!

What's in your box?

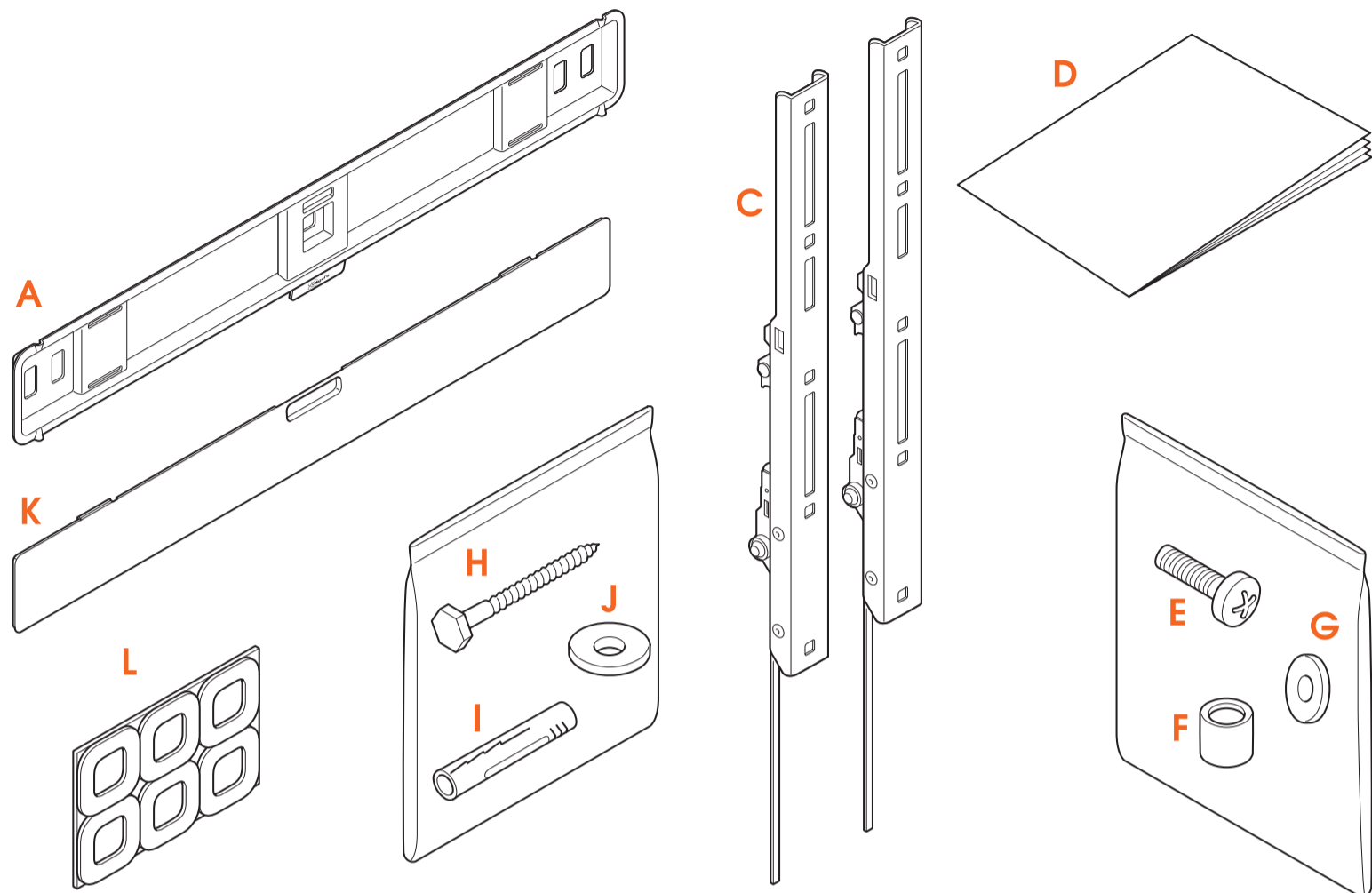

- Something missing? Make sure your packaging has everything in place:

A. Wall mount

C. Strips

D. Safety instructions

E. Bolts for fastening strips on TV (see contents below)

F. Spacers

G. Washers Ø 18 mm

H. Screws

I. Plugs (fischer® DuoPower)

J. Washers Ø 22 mm

K. Cover

L. Protective TV patches

- Contents of the TV fasteners kit:

TVM 3210 Series:

- 4x M4*12mm bolts
- 4x M4*25mm bolts
- 4x M6*12mm bolts
- 4x M6*25mm bolts
- 4x M6*35mm bolts
- 4x M8*12mm bolts
- 4x M8*25mm bolts
- 4x M8*45mm bolts
- 4x M6 washer
- 4x spacer 10mm

TVM 3410/3610 Series:

- 4x M6*12mm bolts
- 4x M6*25mm bolts
- 4x M6*35mm bolts
- 4x M8*12mm bolts
- 4x M8*25mm bolts
- 4x M8*45mm bolts
- 4x M6 washer
- 4x spacer 10mm
- 4x spacer 5mm



You don't need all fasteners to mount your TV. Store the rest for later or other use!

Got your tools ready?

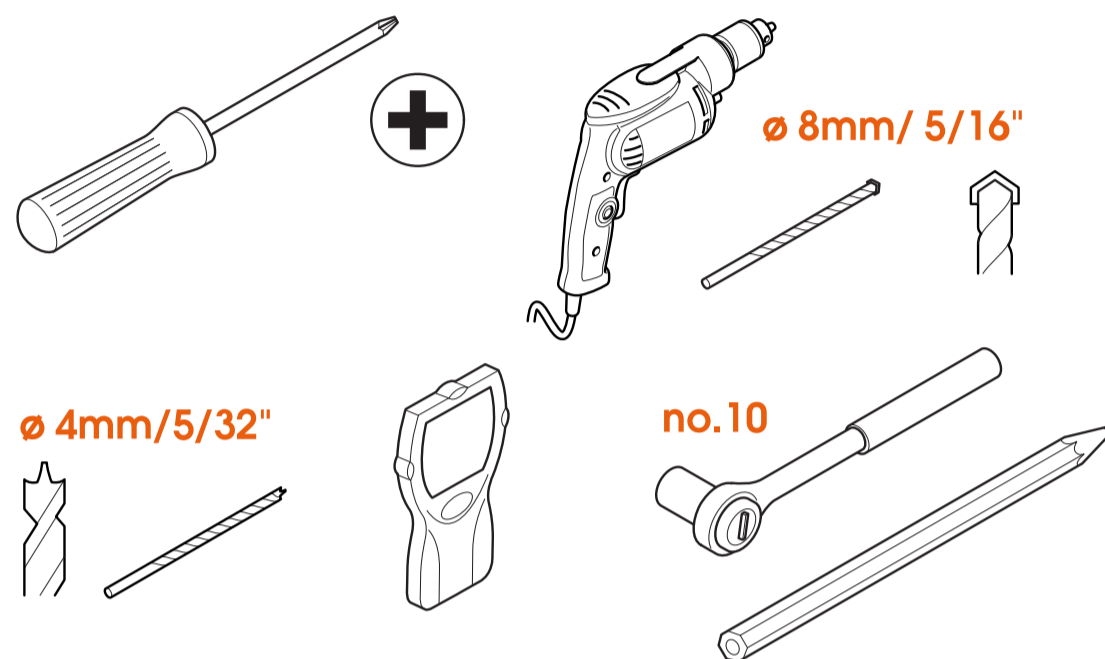

- Don't start without all the necessary tools:
 - Crosshead screwdriver
 - Drilling machine
 - 8mm or 5/16" concrete/brick drill (for concrete/brick walls only)
 - 4mm or 5/32" wood drill (for wooden walls only)
 - Stud finder (optional)
 - Socket wrench
 - Pencil

Take care of your safety

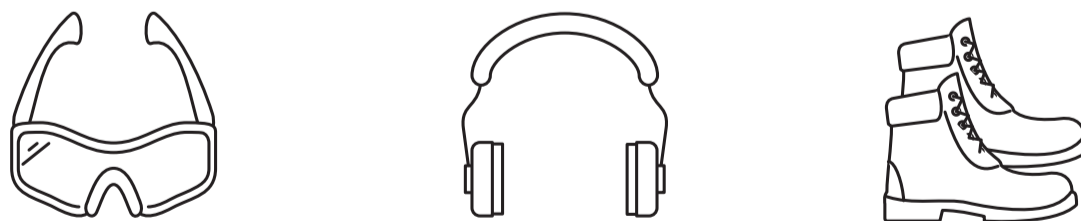

- Who cares about looking cool? Always wear personal protective equipment:
 - Eye protection
 - Ear protection
 - Safety shoes

Ready... set... get installing!

Step 1: Attach the strips to the TV

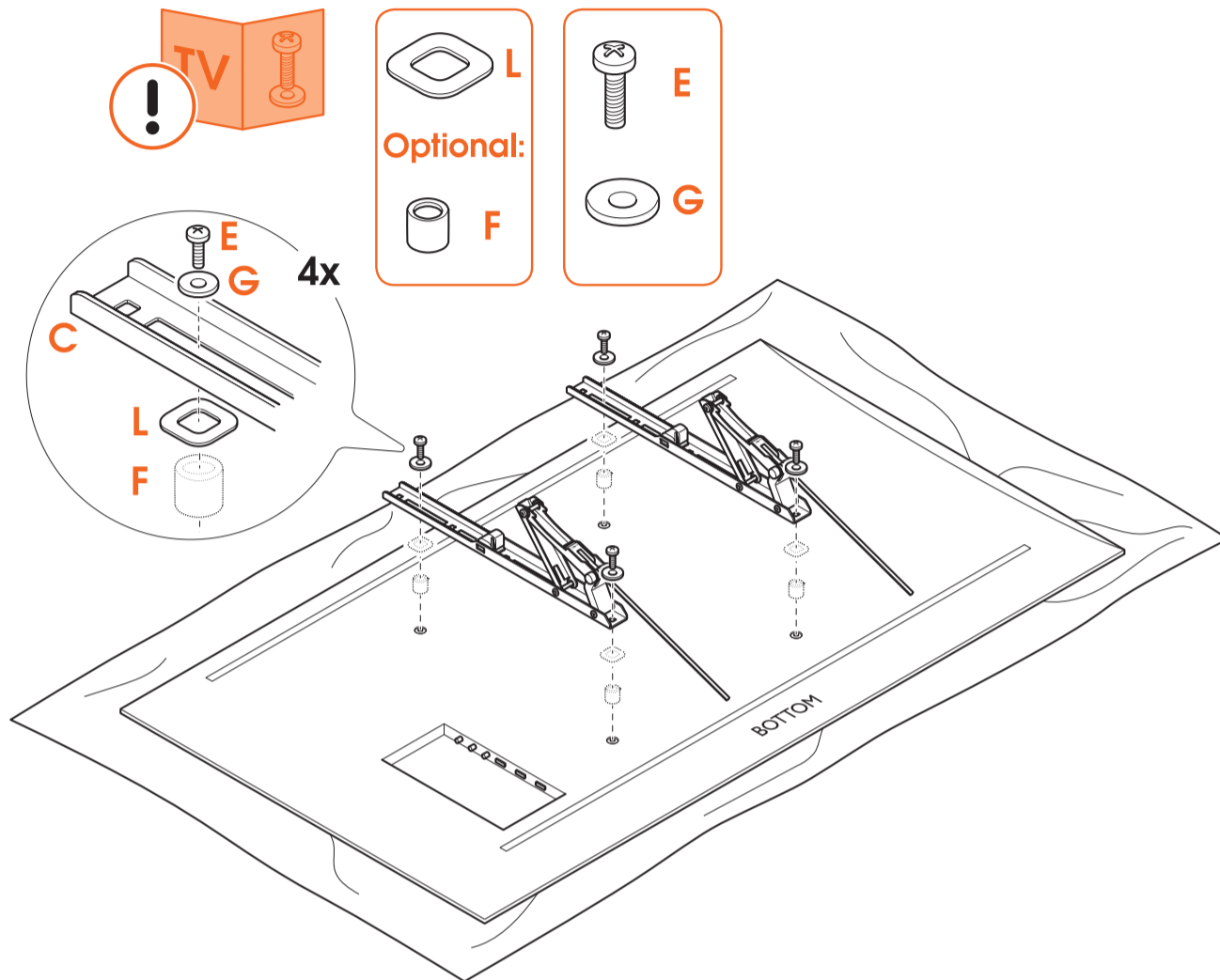

1. Put the **protective TV patches** (L) on the **strips** (C).
2. Put the TV carefully on a clean surface without any obstacles.
3. Open the tilt strips with a screw driver.

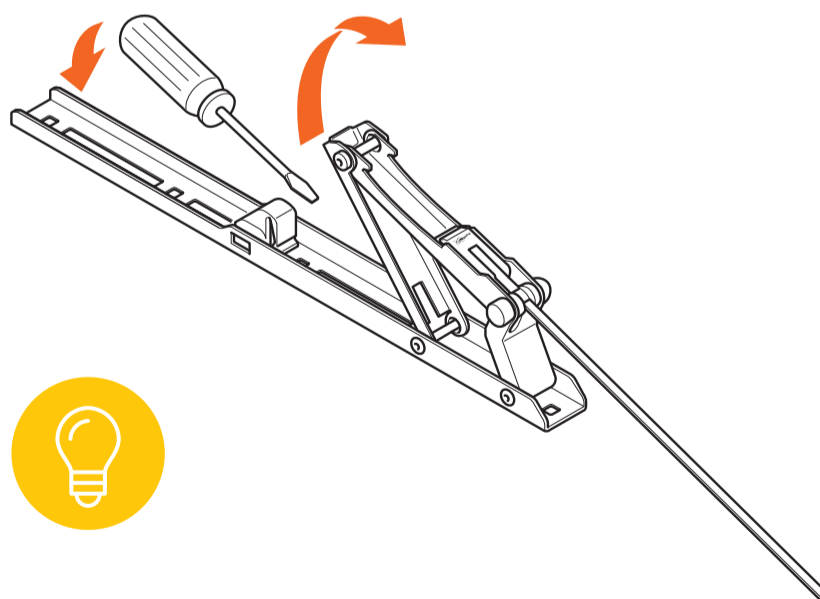

4. Screw the **strips** (C) on to the TV with the **bolts** (E). Make sure the **strips** (C) are at the same height and do not stick out.



Are you missing any bolts? Or need different ones? The friendly team at Vogel's Consumer Care are waiting to help: vogels.com/contact



Make sure that the release cords are at the bottom of the TV when attaching the strips.

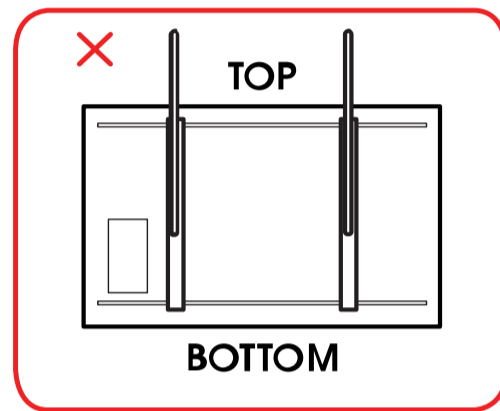
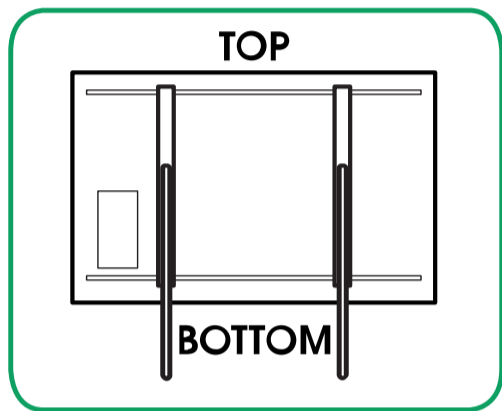

Make sure bolts and spacers are positioned correctly.

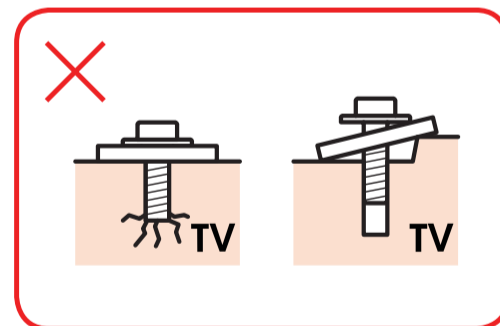
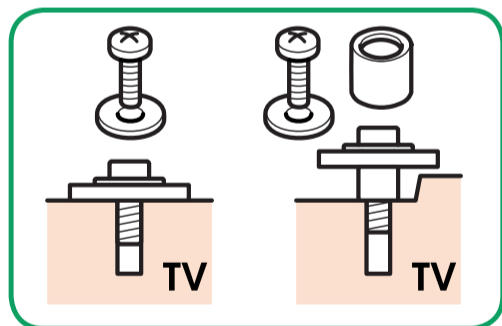

Refer to the user manual of your TV for the correct mounting material.

Step 2: Attach the wall mount to the wall

How well do you know your walls? What they're made of matters more than you think...

Concrete/Brick wall



Don't drill yet! Try our free [DrillRight™ AR app](#) to find just the right height and mark the first hole, easily.

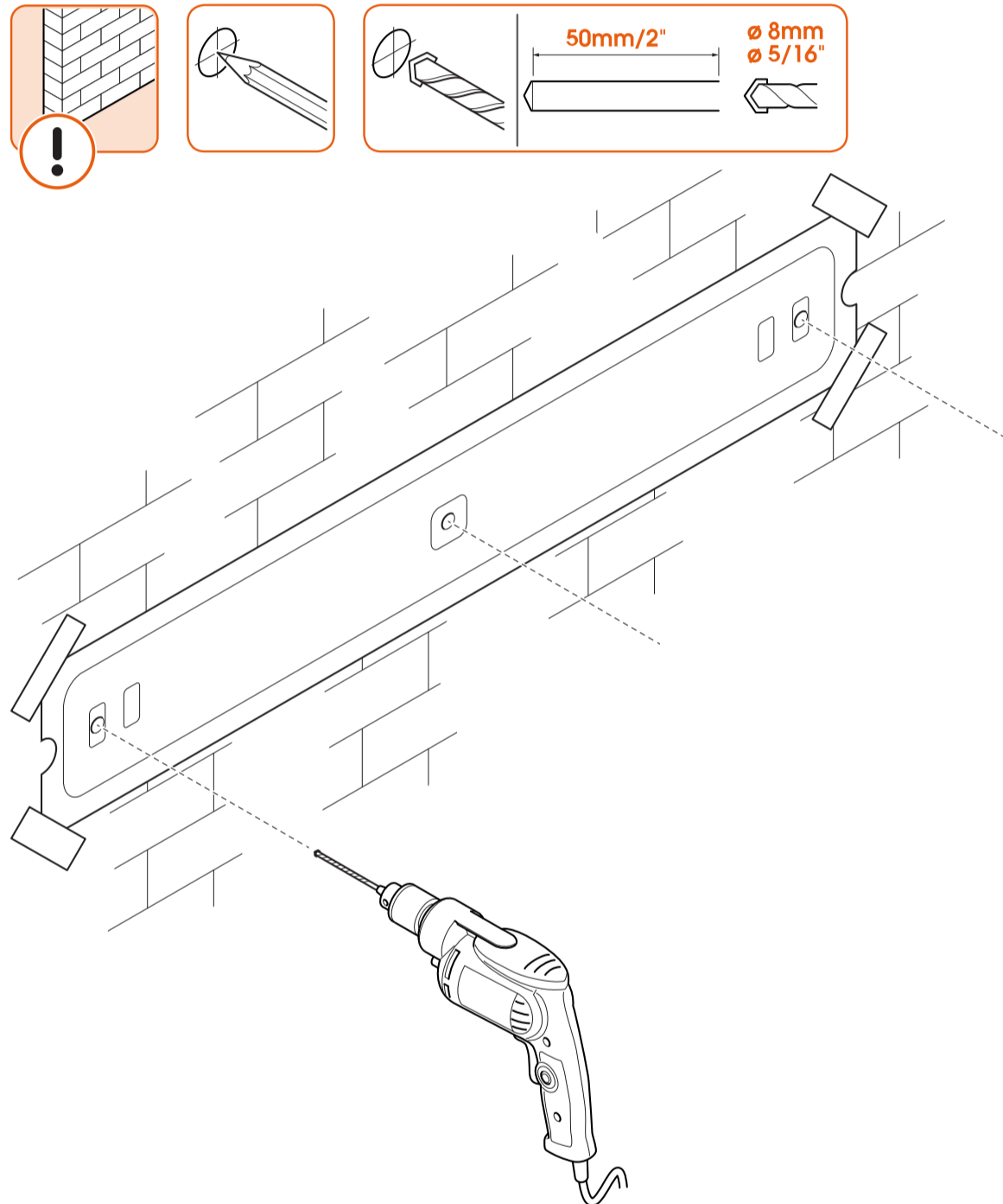

1. Find the perfect spot for drilling with our [DrillRight™ AR app](#) and the included drilling template.
2. Drill the holes.



How deep do you drill? Check the length of the screw (not the plug!) to find the right depth – this stops things from breaking.

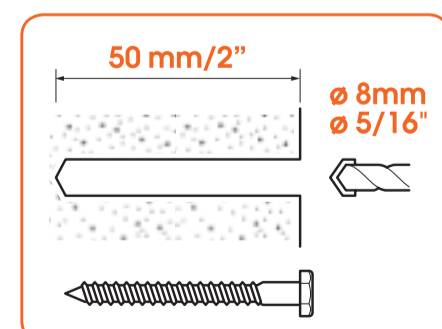

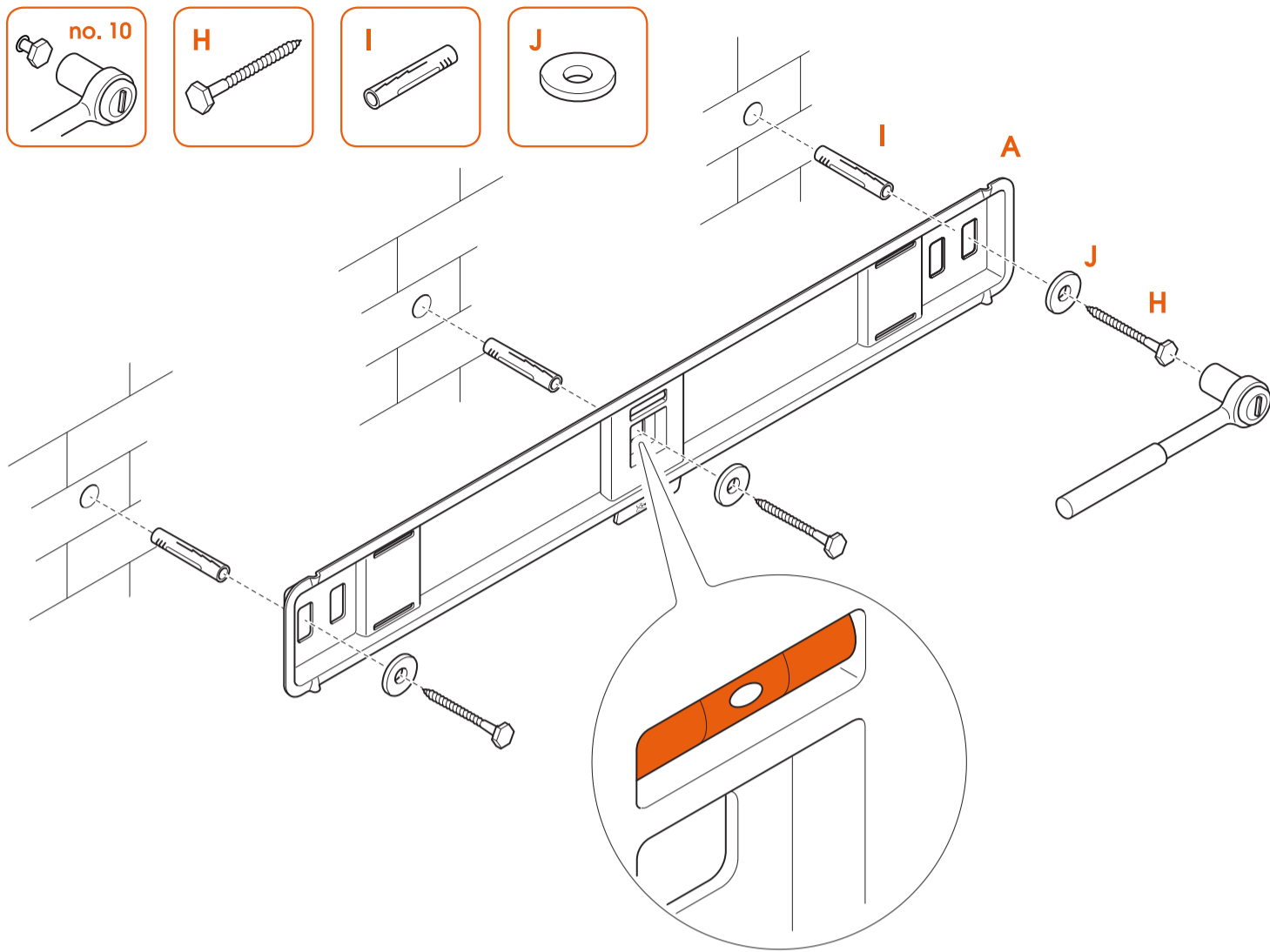

3. Attach the **wall mount** (A) to the wall with the **screws** (H), **washers** (J) and **plugs** (I). Use the spirit level to level the wall mount.



Lubricate the screws for easy screwing in.

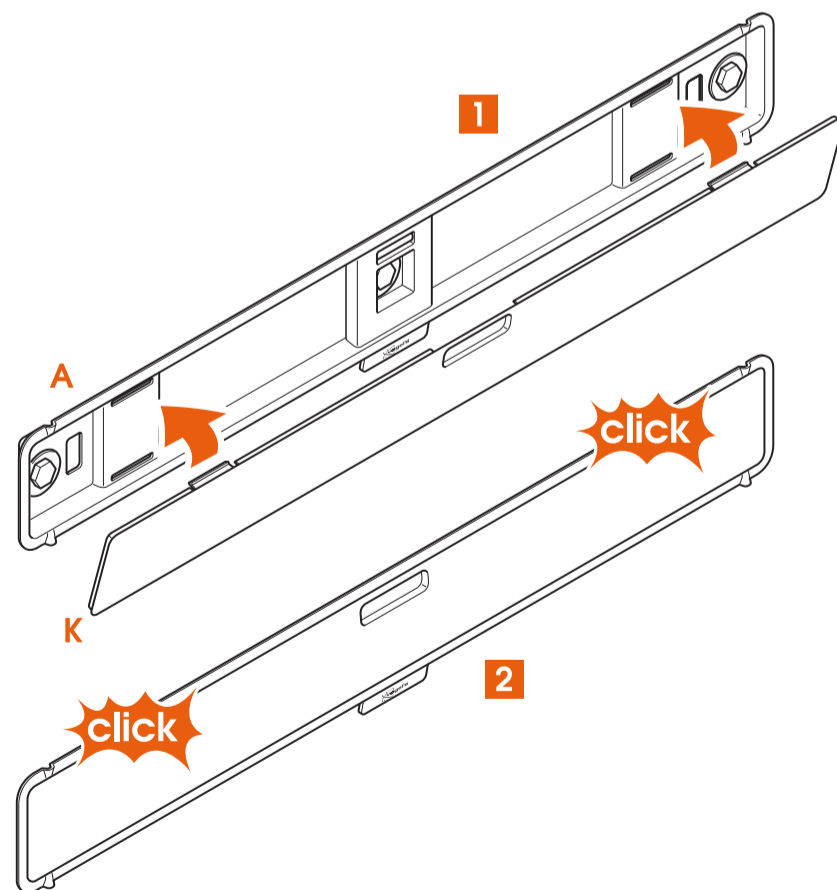

4. Click the **cover** (K) into place. Simple!

Wooden wall with studs



TVM 3200 and TVM 3210 Series are not suitable for mounting on stud walls, without special mounting material. Ask your installer, specialist supplier or the Vogel's Consumer Care team at www.vogels.com/contact for more information.



Don't drill yet! Try our free [DrillRight™ AR app](#) to find just the right height and mark the first hole, easily.

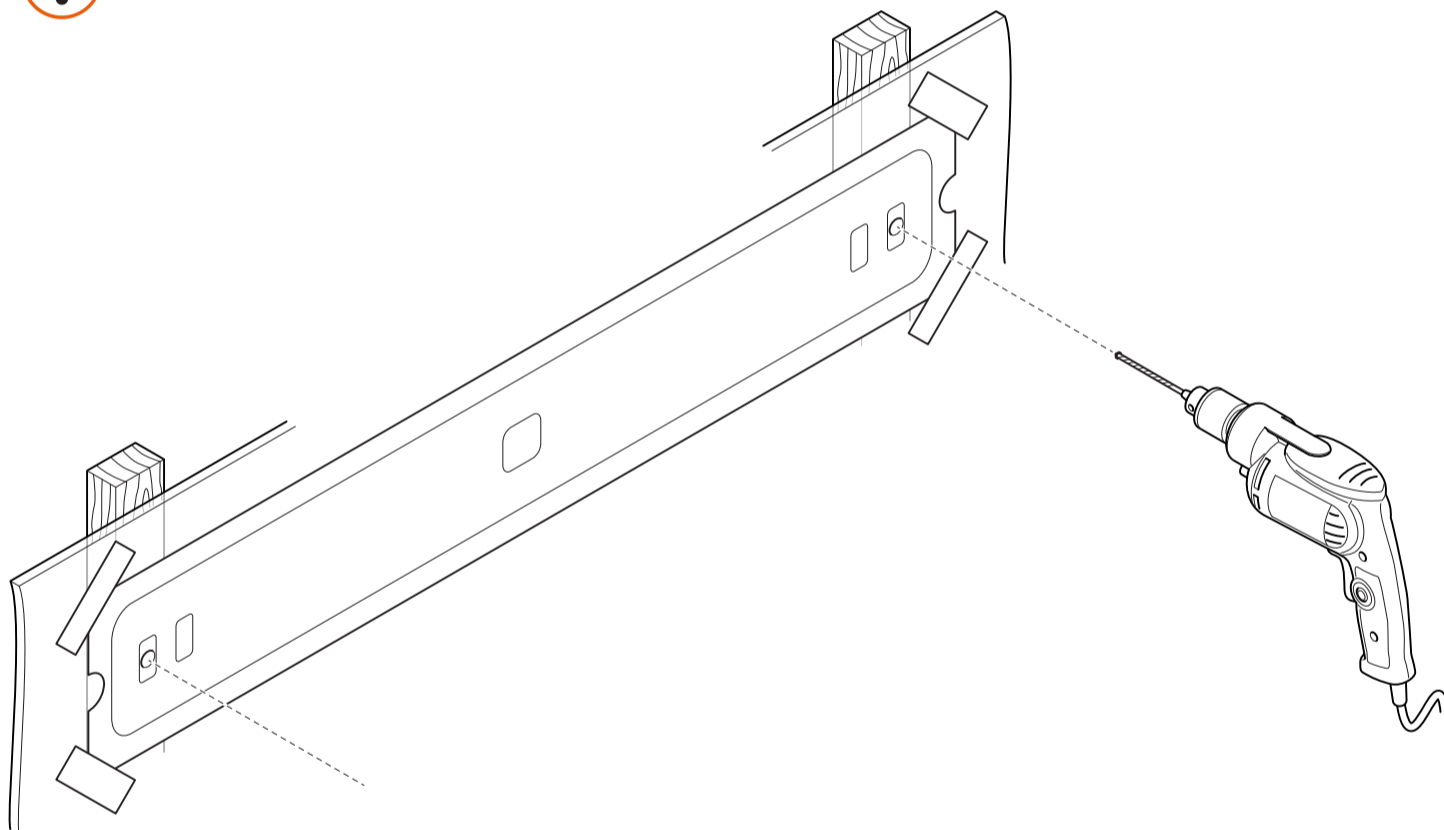

1. Don't just guess! Always use a **stud finder** to determine the position of studs.
2. Find the perfect spot for drilling with our [DrillRight™ AR app](#) and the included drilling template.



The inner 2 holes of the wall plate of the TVM 360x/361x Series are only intended for use for the TVM 360x Series. Do not use these for the TVM 361x Series.

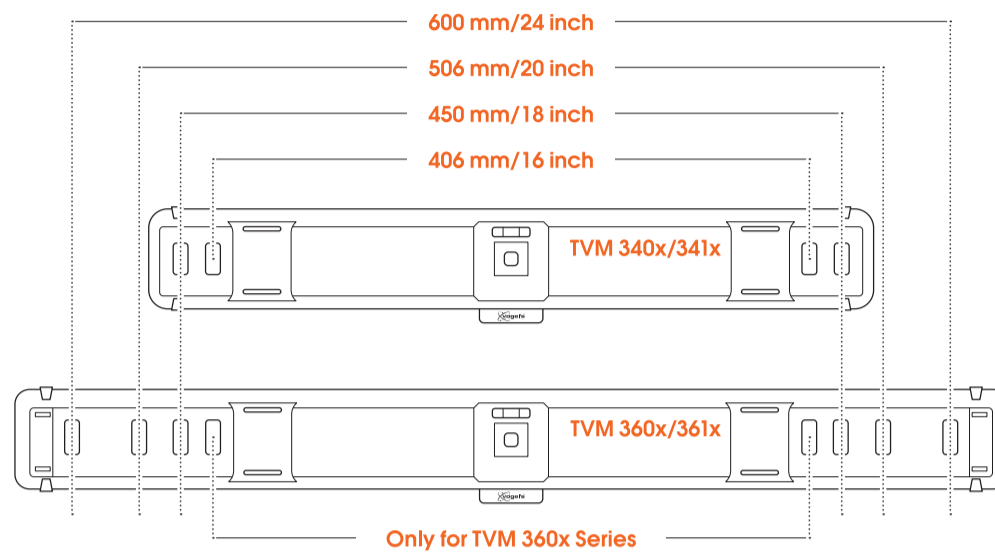

Don't destroy your belongings! The wall mount must always be attached to the studs.

3. Now for the fun part... drilling the holes.

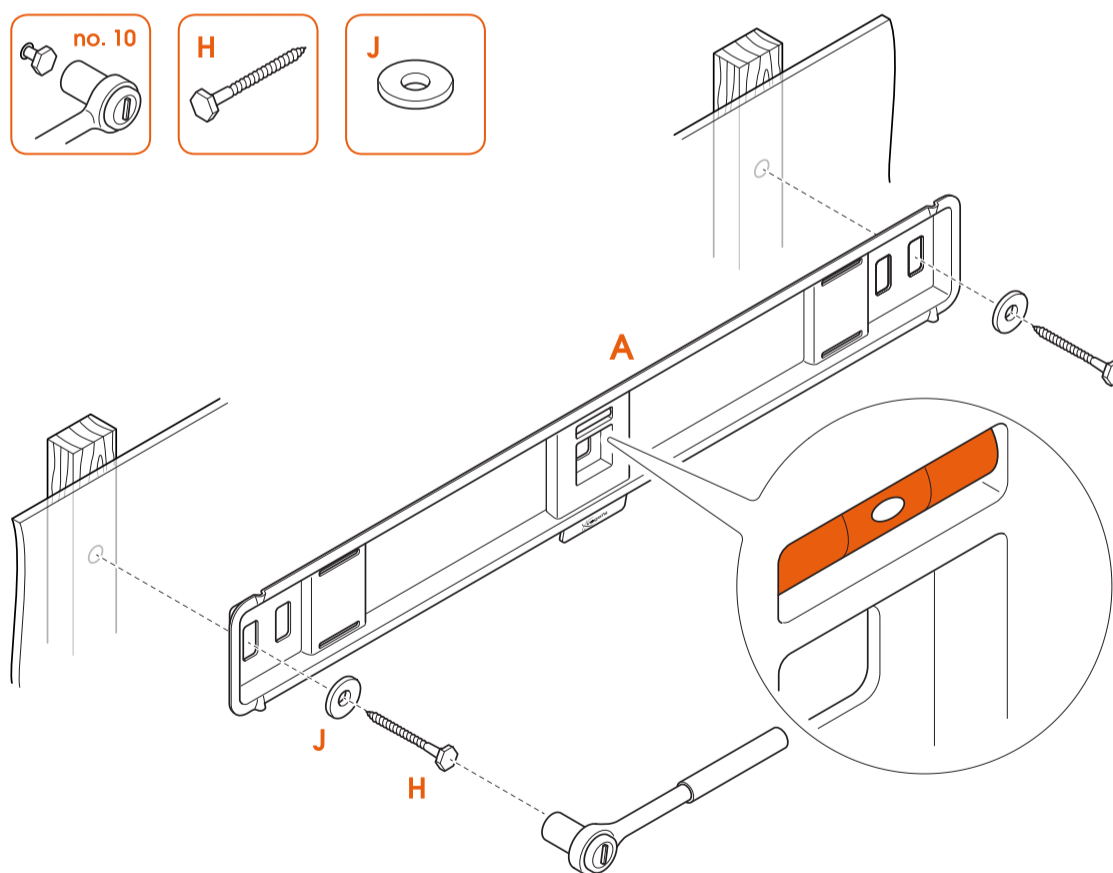

4. Attach the wall mount (A) to the wooden wall with the screws (H) and washers (J). Use the spirit level to level the wall mount.



Lubricate the screws for easy screwing in.

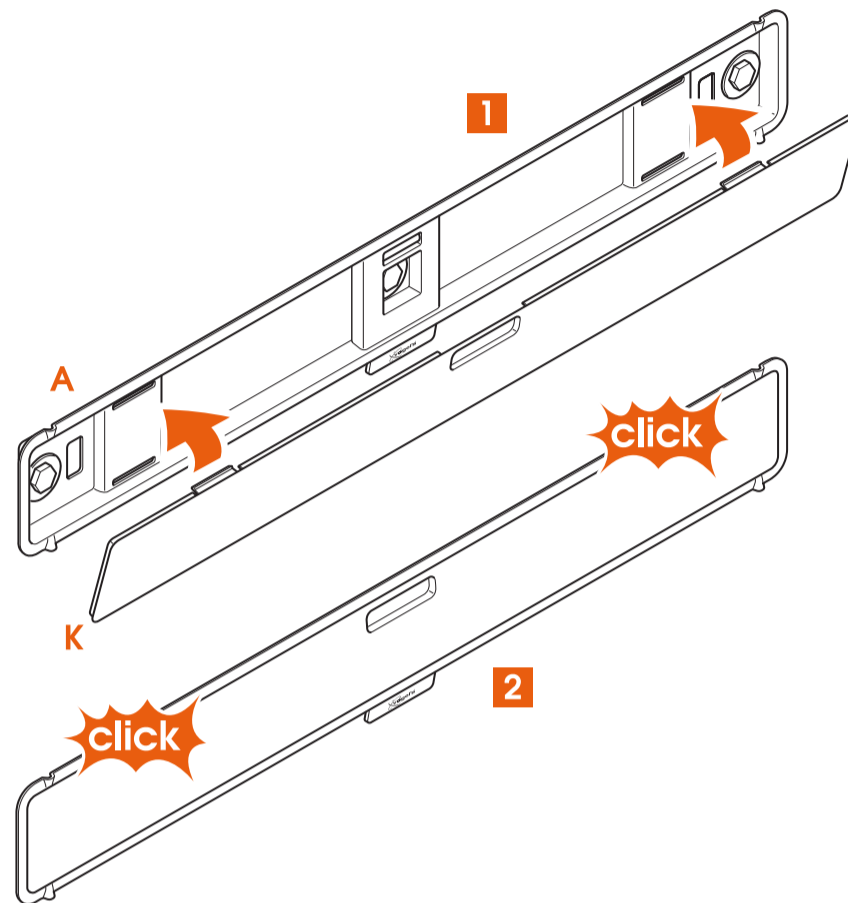

5. Click the **cover** (K) into place. Simple!

Other wall type/I don't know my wall type



If your wall is a little special – for example, hollow bricks, metal stud walls, wood panels or plasterboard – or you simply aren't sure, don't worry! Just ask your installer, specialist supplier or the Vogel's Consumer Care team at www.vogels.com/contact.

Step 3: Attach the TV to the wall mount

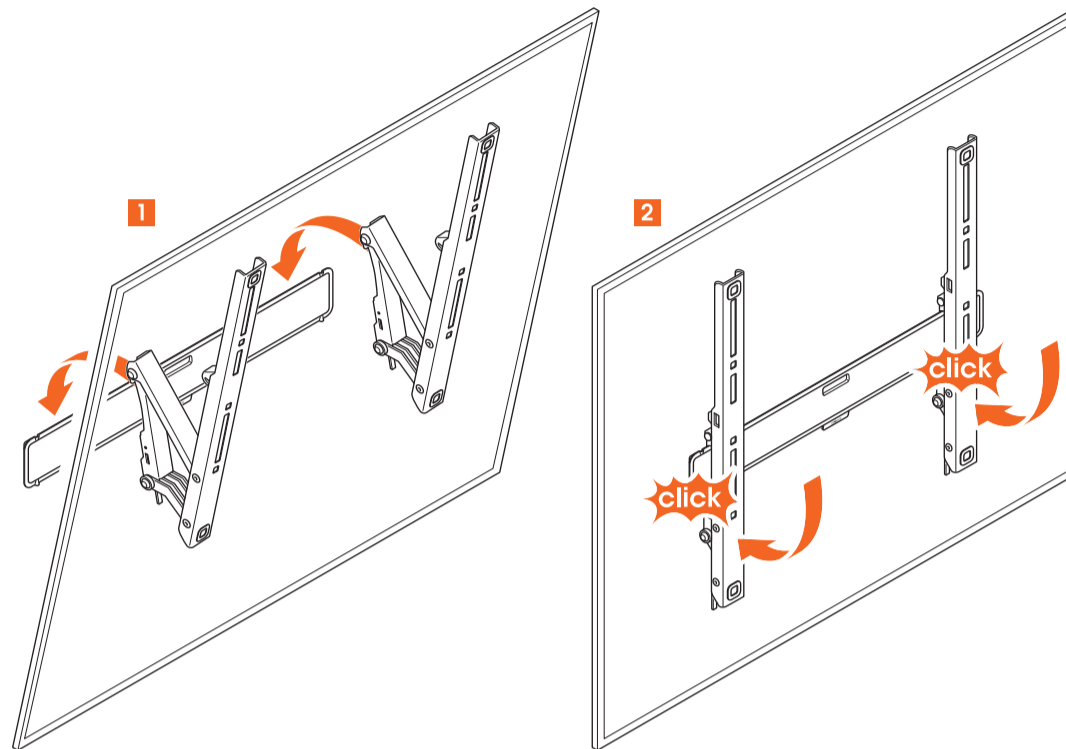

1. Make sure the tilt strips are still open.
2. Carefully lift and attach the TV to the **wall mount** Ⓐ.
3. When you hear a satisfying click (ClickLoc™ Safety System), you know your TV is safely in place.



Lifting your TV is a two-person job. Don't be bold!

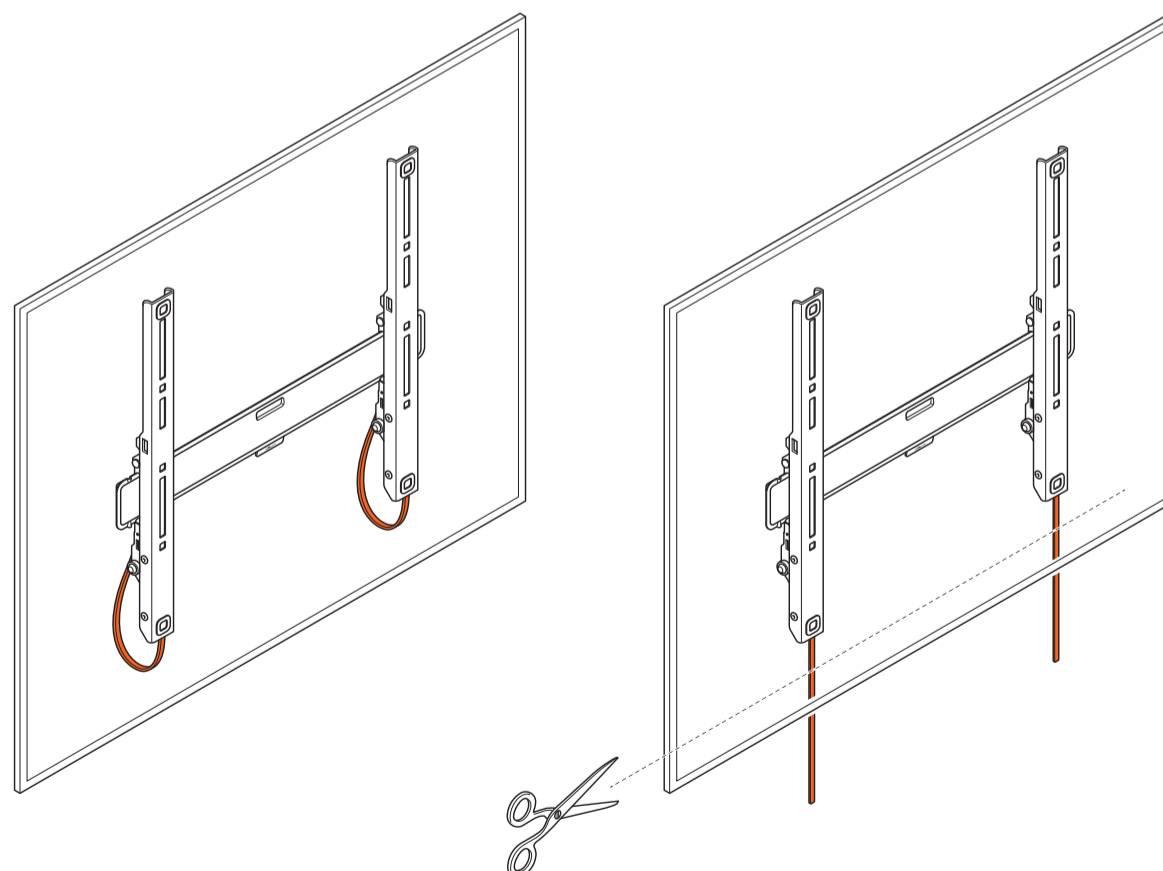

4. Optional: Choose one of the following:
 - Tuck the excess **release cords** between the wall and the TV to hide them, or...
 - Cut the excess **release cords**.

Job done now! Enjoy watching your TV!

Handy features

Tilt to avoid reflections

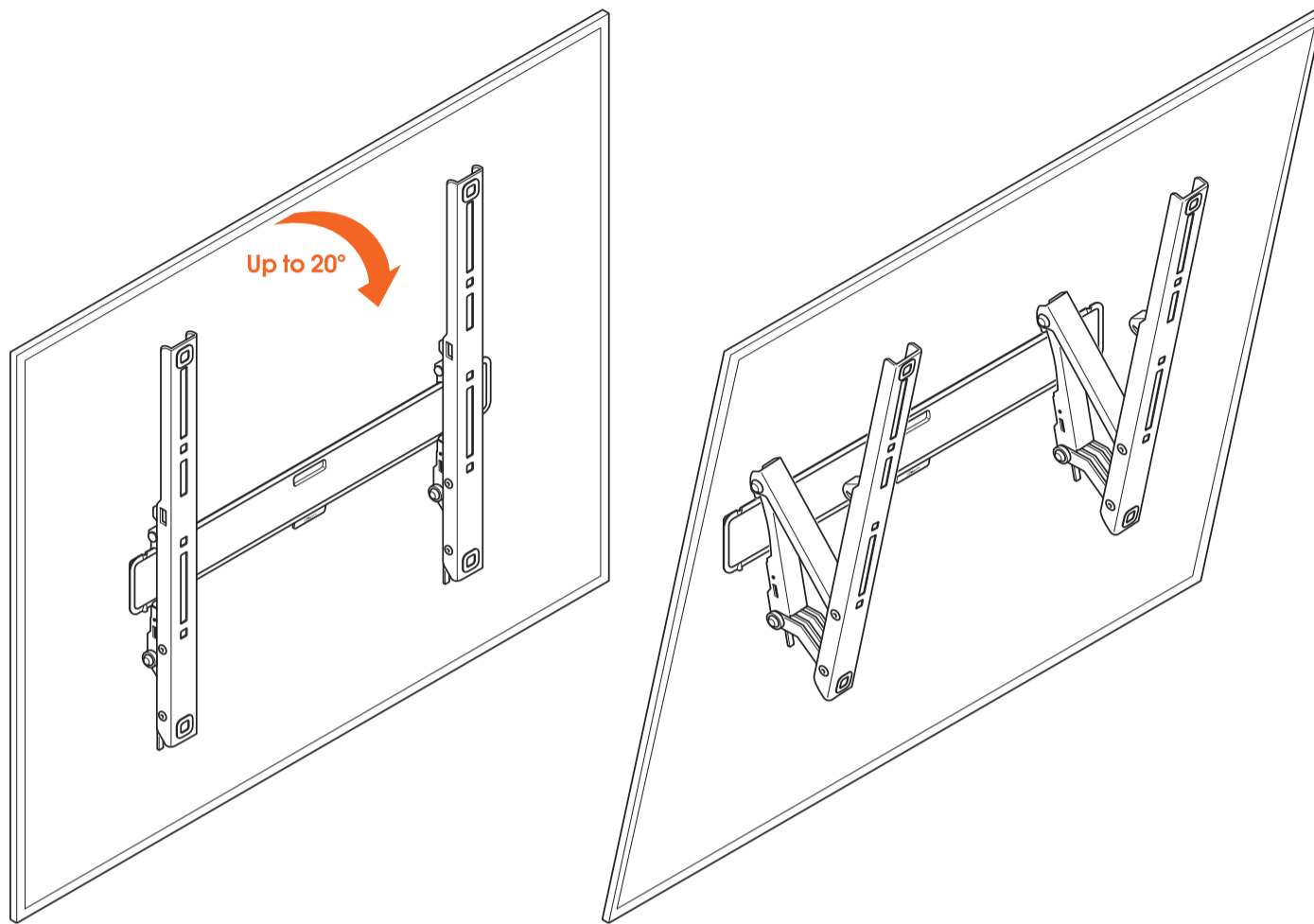

- Need to avoid reflections? Tilt your screen easily up to 20°, without the need for tools. Just pull the TV forward to your wishes.



Having a cable mess? Do you need inspiration about how to hide and guide your cables or how to place other TV accessories? Take a look at our website [vogels.com](https://www.vogels.com)!

Removing your TV

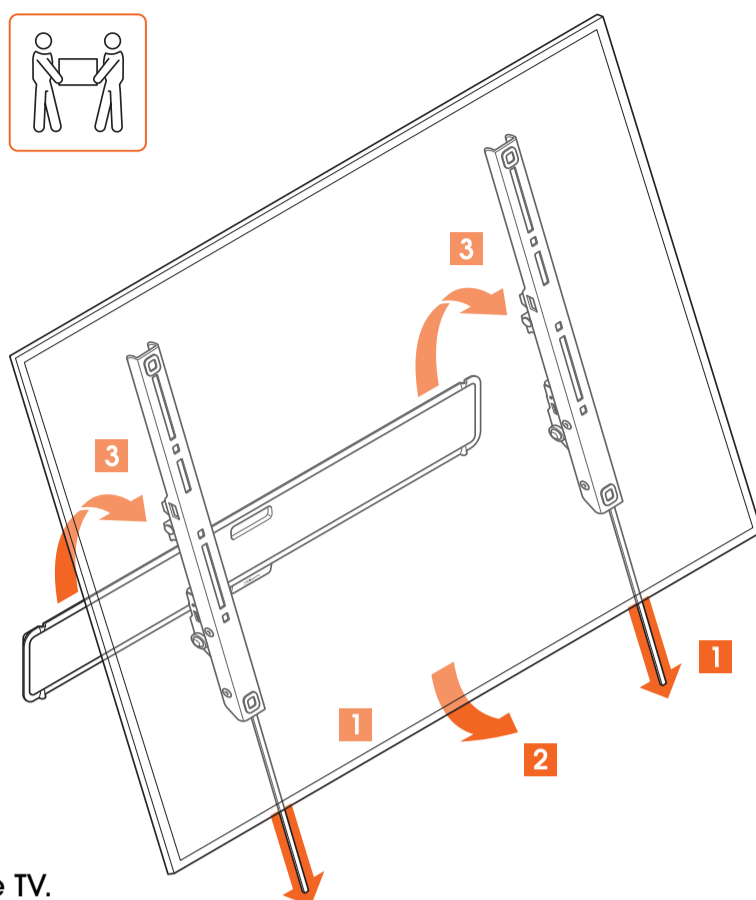

1. Pull the **release cords** to unlock the TV.
2. Remove the TV, and put it down somewhere safe.



Again, lifting your TV is a two-person job. Always get help.

Tell us how you feel!

Your opinion matters more than you might think. It helps us make better products, and helps other customers make informed choices.

Share your feedback, and sign up to win Vogel's products!

Simply visit vogels.com/review for sharing or the Terms and Conditions.

Confused? Unsure? Going crazy?

There's plenty of help waiting for you, online:



info@vogels.com
www.vogels.com/contact



[facebook.com/
VogelsForSure/](https://facebook.com/VogelsForSure/)



[instagram.com/
vogels_official/](https://instagram.com/vogels_official/)



[www.youtube.com/
c/VogelsForSure](https://www.youtube.com/c/VogelsForSure)

Simple troubleshooting

Found a problem you can't fix? Don't panic... try these!

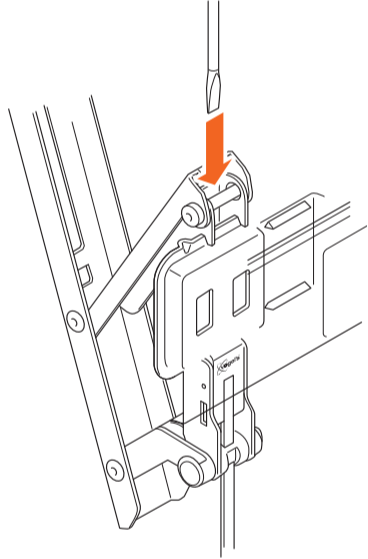
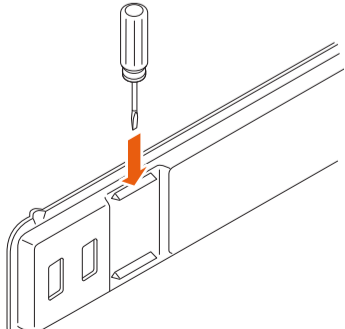
Problem	Cause	Solution
'I don't have the right bolts for my TV!'	The world of TV technology is always changing – it can be hard to keep up sometimes. So, it might be the case that the correct bolt size is not included... you're just too advanced!	Just ask Vogel's Consumer Care to request a service kit, and we'll send everything you need. Click here to contact Vogel's Consumer Care.
'I have a lot of leftover bolts, is something wrong?'	No, you did it very well! You only need 4 bolts to install the mount to your TV. Because of all the different types of TVs, we have included the most common sizes for the most sold TVs.	Don't waste the other bolts, save them! You can use them for another TV when you buy a new one or use it elsewhere.
'I broke my release cord!'	You don't know how strong you are... sometimes when the cord is pulled too hard, it can snap.	Don't panic. Just Push the ClickLoc™ Safety System downwards in both strips, using a long screwdriver or allen key.
		
		For new release cords, please click here to contact Vogel's Consumer Care.
'My wall screws have snapped!'	You might not be drilling deep enough... or your drill could be too blunt, so that the hole is too narrow and the screw gets stuck.	Use another hole in the wall plate to fix the wall mount to the wall. Make sure you use a sharp drill of the correct size. Use the size of the screw as indication of the depth to be drilled.
'My cover is stuck!'	If the space between your wall and your wall mount is a little too tight, things can get tricky to reach.	Push a small screwdriver between wall and wall mount to push the snap hooks down to release.
		

FAQs

'Where can I request the correct bolts for my TV (a service kit)?'

Whatever you need, simply contact your local Vogel's dealer or Vogel's. [Click here](#) to contact Vogel's Consumer Care.

'Where can I find installation videos?'

The installation video can be found at the product page of your product on our website. It can also be found on our YouTube channel:
www.youtube.com/c/VogelsForSure

'What if I need spare parts?'

If you require a spare part, please contact your local dealer or Vogel's. [Click here](#) to contact Vogel's Consumer Care.

'Where can I find the drilling template?'

The drilling template is printed on the inlay card in the box. You can cut it out for your convenience.

'How high do I need to hang my TV?'

The center of your TV should ideally be positioned at eye level, while seated. Download and use the free [DrillRight™ AR app](#) to determine the height of the TV and to mark the first hole.

'How high do I need to hang my TV in case of a tilt mount?'

When a wall mount with tilt function is used, your TV can be mounted above eye level.

'Which bolts or screws do I need to use?'

Vogel's offers a complete assembly kit with all mounting materials included in the box, for both your TV and wall. Do you miss the correct bolts for your TV? Please contact your local Vogel's dealer. [Click here](#) to contact Vogel's Consumer Care.

'Why do you use Fischer© plugs?'

The Fischer© DuoPower plug is widely regarded as the best standard in plugs. Don't settle for less!

'What is VESA?'

VESA is a standard pattern of mounting location holes on the back of a TV which allows many standard TV mounts to be easily fitted to your TV.

Go green!

We care about the planet. If you're getting rid of the packaging or the TV mount itself, please visit your local recycling facility, or contact your municipal office. Recycling matters!



Guarantee



Thanks again for choosing Vogel's! Just like every product we make, your new purchase is made of durable materials and is based on a meticulous design. That is why Vogel's gives you a 10-year guarantee for defects in materials and manufacturing.

1. Vogel's guarantees that if during the guarantee period of a product, faults arise due to defects in manufacturing and/or materials, it will, at its discretion, repair or if necessary replace the product, free of charge. A guarantee for normal wear and tear is hereby expressly excluded.
2. If the guarantee is invoked, the product should be sent to Vogel's, together with the original purchase document (invoice, sales slip or cash receipt). The purchase document should clearly show the name of the supplier and the date of purchase.
3. Vogel's guarantee shall lapse in the following cases:
 - If the product has not been drilled, installed and used in accordance with the Instructions for Use;
 - If the product has been altered or repaired by someone other than Vogel's;
 - If a fault arises due to external causes (outside the product) such as for example lightning, water nuisance, fire, scuffing, exposure to extreme temperatures, weather conditions, solvents or acids, wrong use or negligence;
 - If the product is used for different equipment than is mentioned on or in the packing.

Vogel's Products BV - Hondsruglaan 93 - 5628 DB Eindhoven - The Netherlands
Vogel's Products BV 2021 © All rights reserved.