

TS2000C

Original

352100.3

EN - Assembly Instruction and User Manual (Page 2)

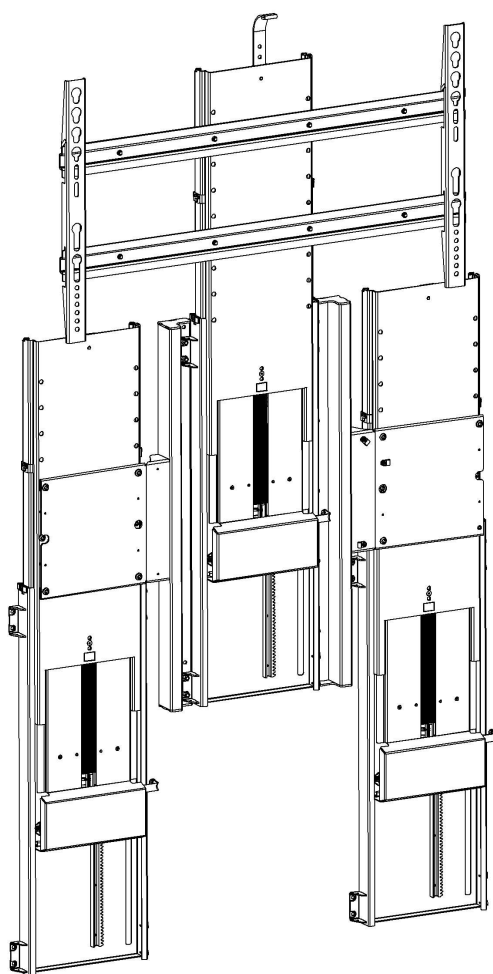

1. Parts

EN

(A) Flat lift

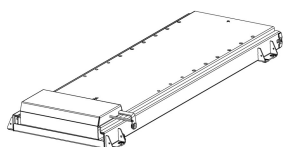

x3

(B) Connector bracket

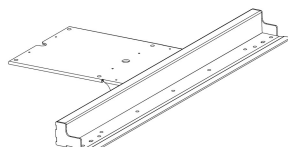

x2

(C) Screw M6x12mm

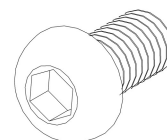

x8

(D) M6 nut

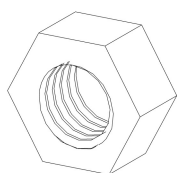

x8

(E) Side plate fix

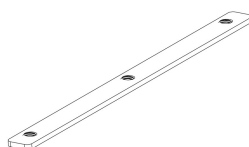

x4

(F) Screw M8x10mm

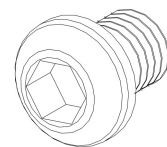

x4

(G) Screw M8x16mm

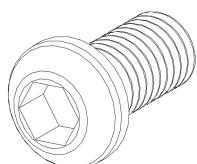

x8

(H) Extender wire

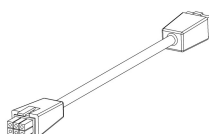

x3

(I) Cableclip

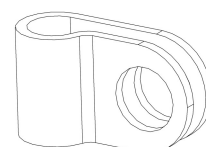

x4

(J) Screw M4x8



x4

(K) Sync box



x1

(L) Power supply

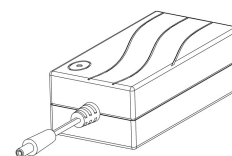

x1

(M) Power cord

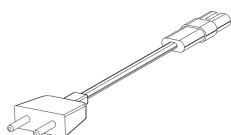

x1

(N) RF remote emitter

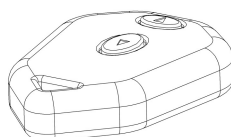

x1

(O) Monitor bracket

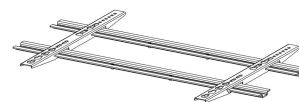

x1

(P) Control panel

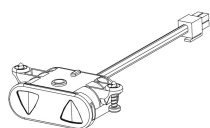

x1

(Q) bushing

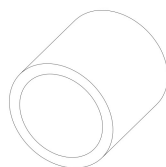

x6

(R) M8 washer

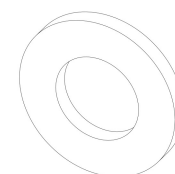

x8

2. Assembly Instruction and User Manual

1 Moving columns

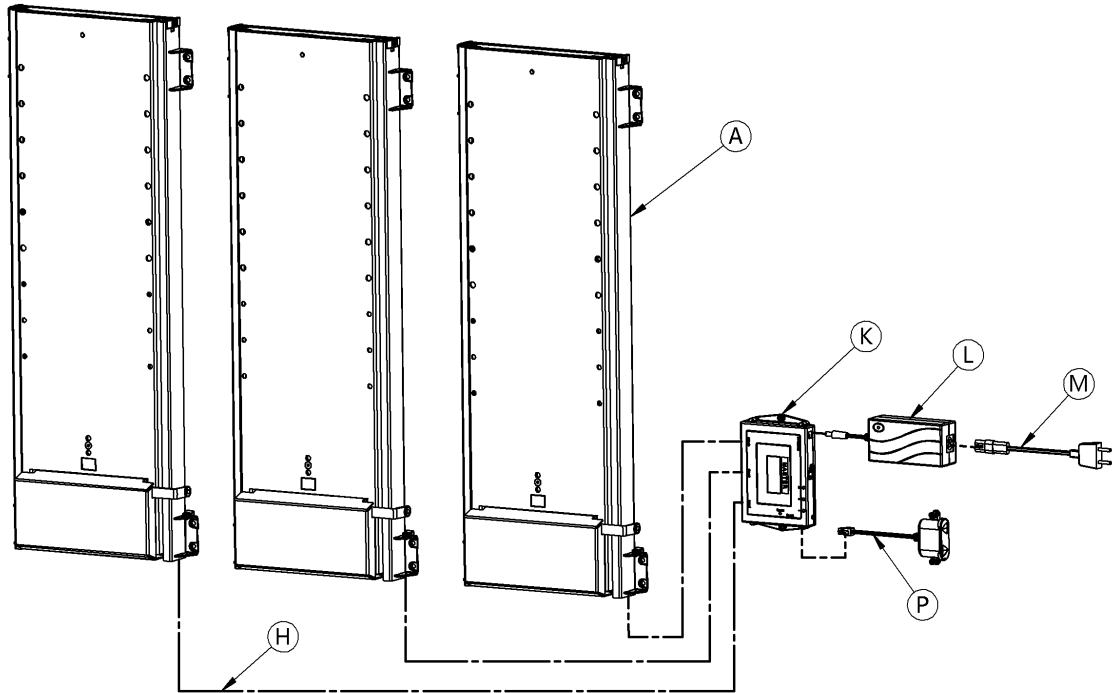

2 Mounting brackets

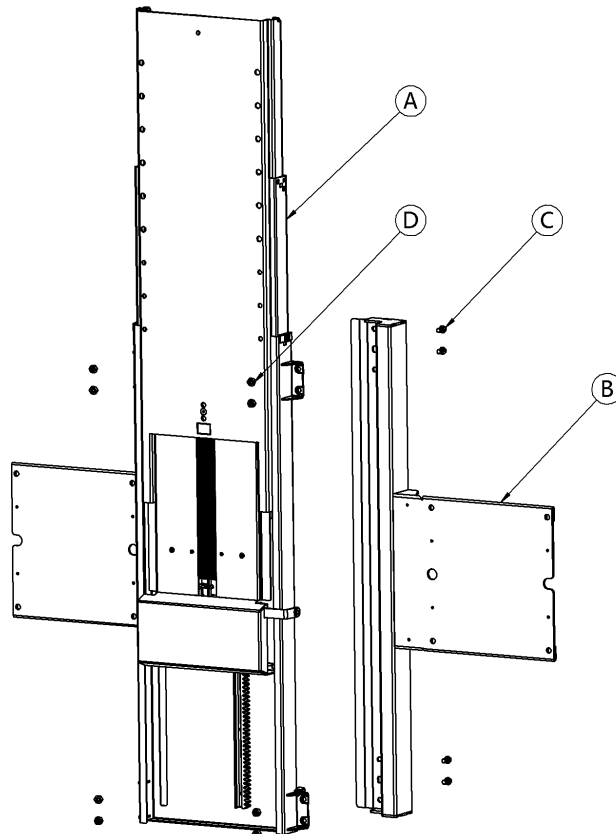

3 Mounting fix plate

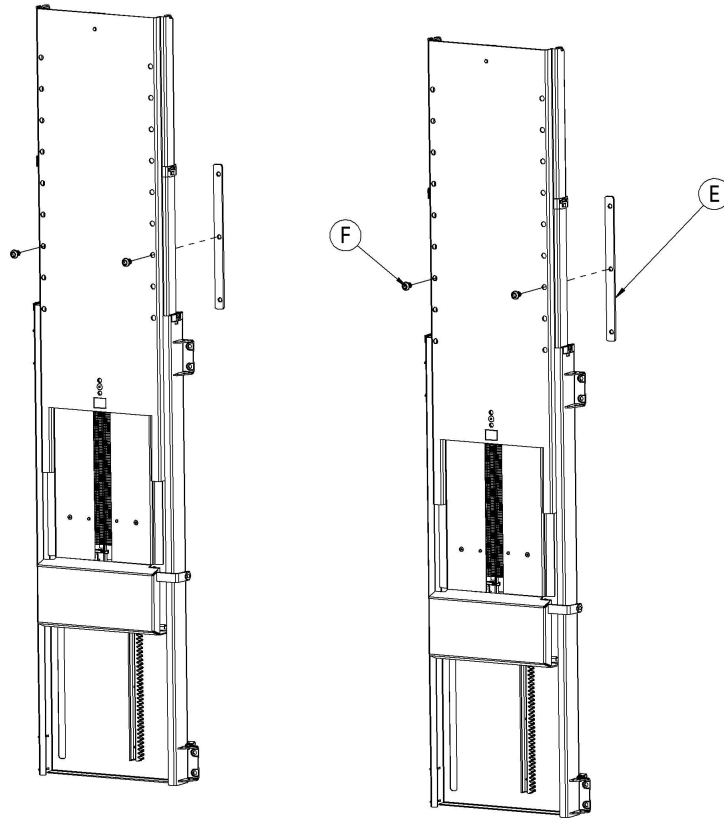

4 Connecting lifts

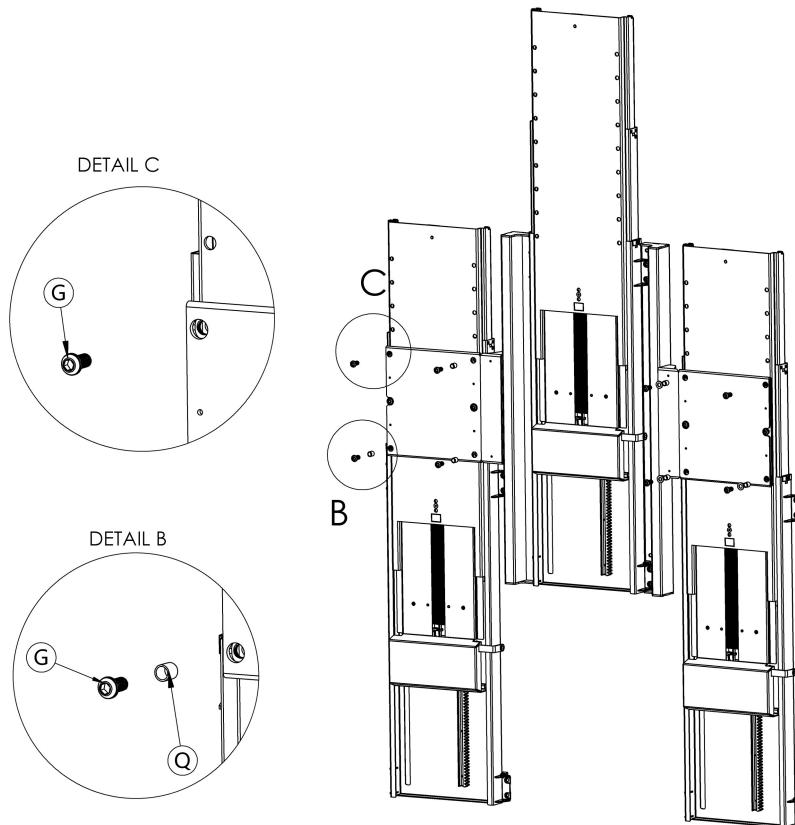

5 Wiring

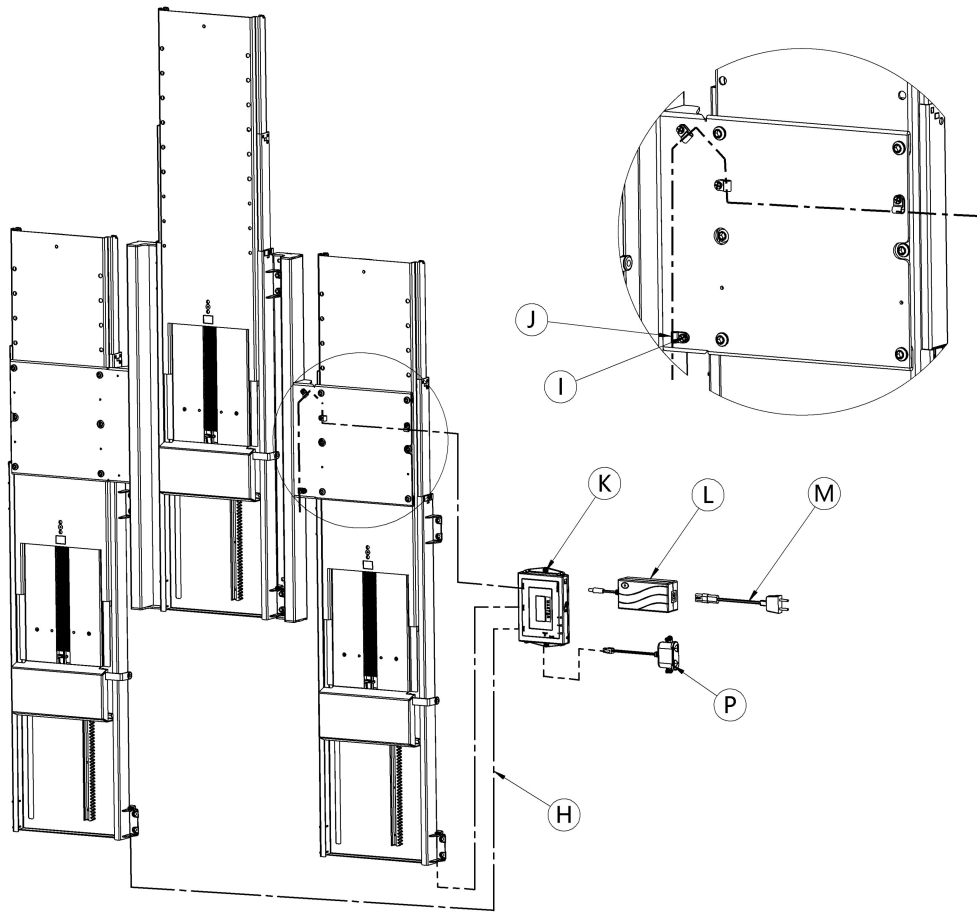

6 Wiring



7 Monitor brackets part 1

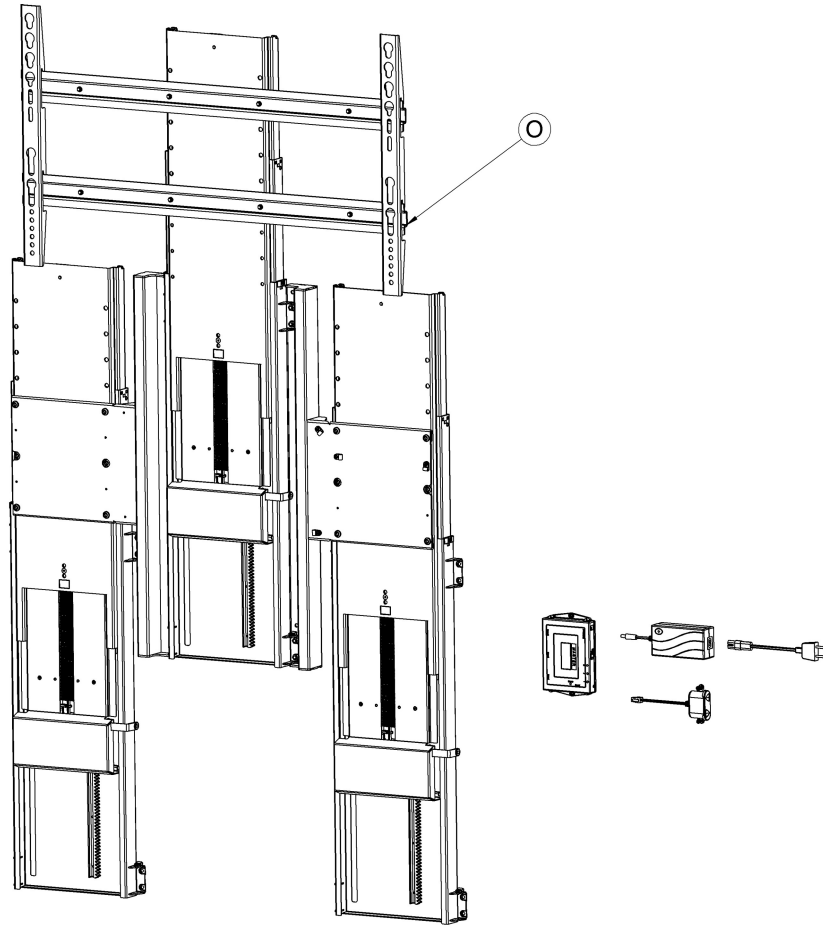

8 Monitor brackets part 2

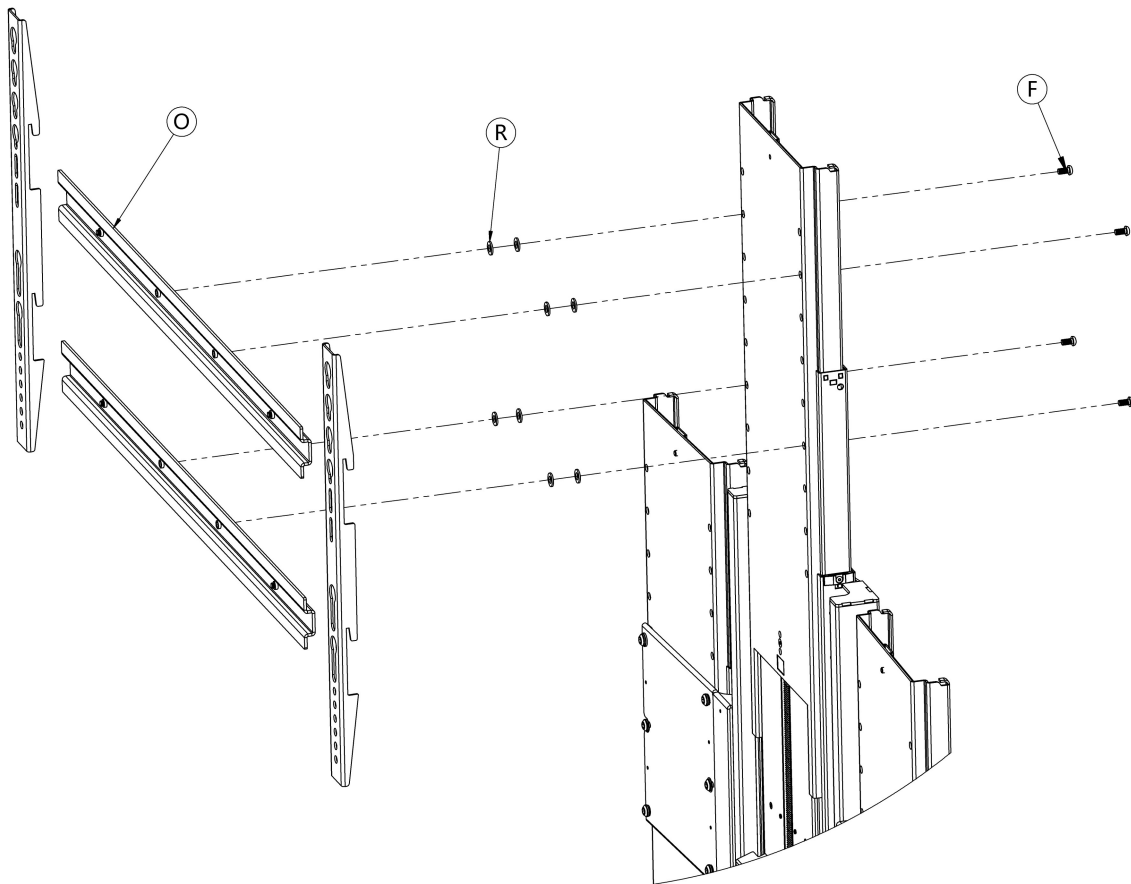

9 Mounting Overview

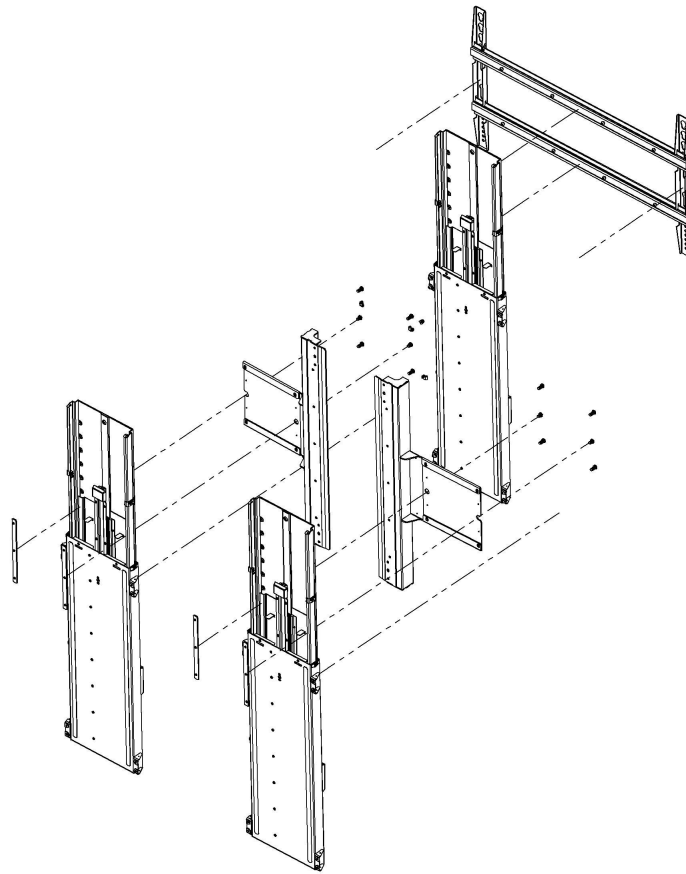

10 Mounting guide

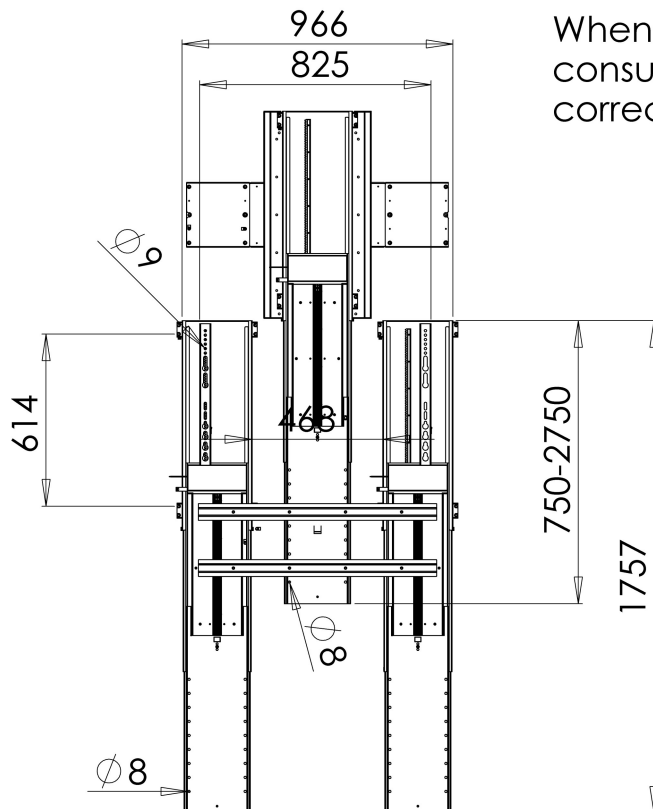

When mounting your lift, please consult these measurements for correct mounting.