

NOVUS TSS support carriage



- High quality infinitely height adjustable support carriage
- Easy mounting of the monitor by quick release with one hand operation, suitable for attachment standard 75/100
- Mounting of flat screens up to 15 kg
- Restrict movement by tightening the joints
- Swivelling and tiltable
- Range: 105 mm
- In high-quality aluminium and metal
- Removable clamping grips for protection from theft
- Obligatory supplement is a TSS column



The weight indicates the maximum load-bearing capacity of the supporting element or the maximum weight of an attachable monitor in kilograms.



The mounting has the mentioned reach in mm.



Novus offers a warranty of 5 years when handled in a proper manner.



The quality statement „German Engineering“ ensures that a product was developed according to German quality standards by our engineering experts. All Novus products carrying the „German Engineering by Novus“ signet are manufactured in our own plants around the world by our own workforce, managed and supervised by our headquarters in Germany.



This machine bears the GS approval of product safety.

Version	Art.No.	EAN Code
 silver / anthracite	963+0119+000	4009729047002

NOVUS TSS support carriage

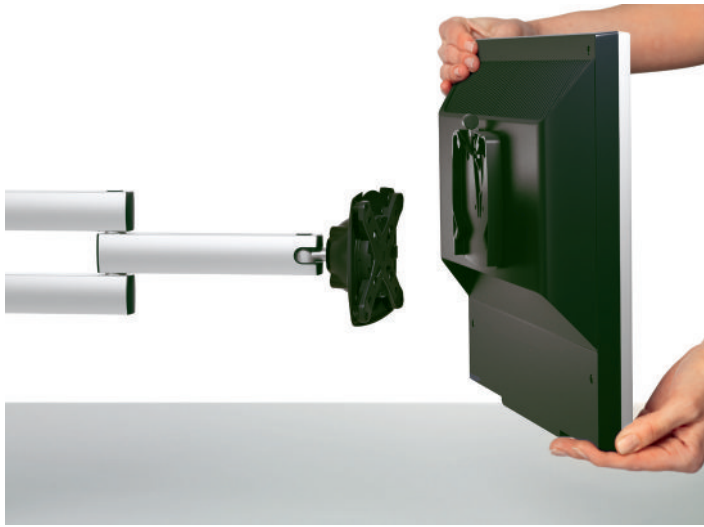

with NOVUS Quick Release for quick and easy monitor change without tools

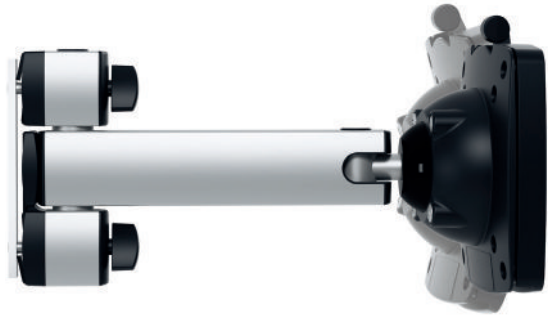

ball-joint for flexible and precise positioning of the monitor

NOVUS TSS column with system clamp 1 (14-40mm)



- Aluminium column with four slots and system clamp 1
- Table mounting with system clamp 1 for a desktop thickness of 14-40 mm
- Available in lengths: 445 mm and 545 mm
- Includes two cable clips
- Suitable for all TSS support elements





Version	Art.No.	EAN Code
  silver	961+0609+000	4009729033661
  silver	961+0639+000	4009729042151



Table mounting with system clamp 1 for a desktop thickness of 14-40 mm



all items with universal clamp 1 can be attached to the product



Novus offers a warranty of 5 years when handled in a proper manner.



The quality statement „German Engineering“ ensures that a product was developed according to German quality standards by our engineering experts. All Novus products carrying the „German Engineering by Novus“ signet are manufactured in our own plants around the world by our own workforce, managed and supervised by our headquarters in Germany.



This machine bears the GS approval of product safety.