



# M81CMxB2B

AVAILABLE COLORS		
	Black with black trim	
	Silver with gray trim	
	Polished aluminum with white trim	
TOTAL MONITOR WEIGHT RANGE		
WT	2.75 to 24.75 lbs	1.25 to 11.20 kg
MAX. ACTUAL MONITOR WIDTH (TWO MONITORS)		
W	28 in	712 mm
PRODUCT WEIGHT		
WT	14.25 lbs	6.5 kg
SHIPPING – INDIVIDUAL PACK ONLY		
L	33 in	835 mm
W	12 in	300 mm
H	7 in	180 mm
WT	18 lbs	8 kg
NOTES		
<ul style="list-style-type: none"> <li>• The VESA bracket cover is black.</li> <li>• The crossbar color matches the VESA color.</li> <li>• Clamp can be separated into two pieces to accommodate installation where a panel is adjacent to the work surface.</li> <li>• Clamp can be flipped to accommodate desks up to 2.8 in (71 mm) thick.</li> </ul>		

## DIMENSIONS

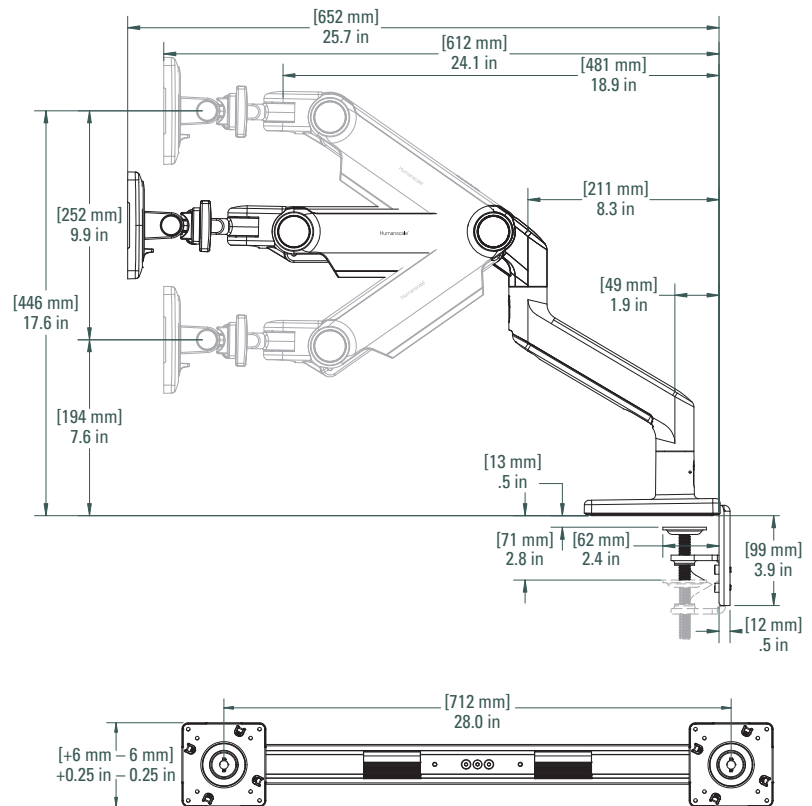

## ROTATION/TILT

