

www.ergotron.com
 USA 1-800-888-8458
 Europe +31 (0)33-45 45 600
 China 86-769-86018920

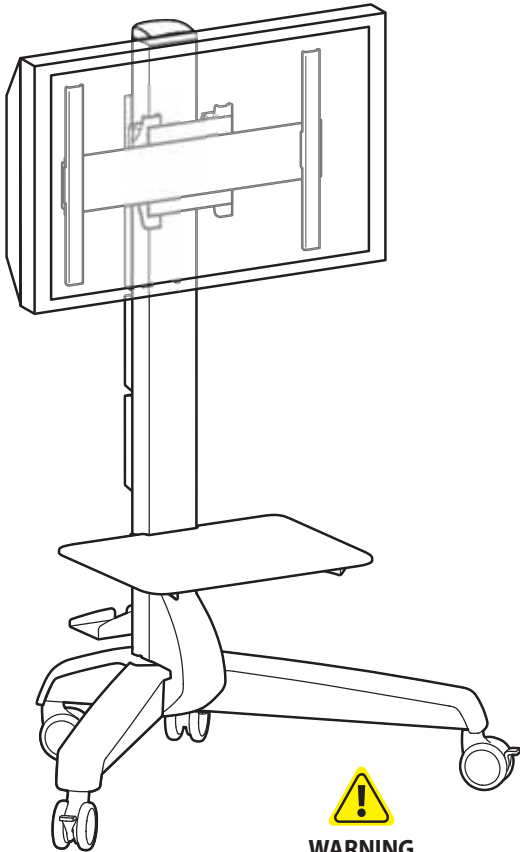

WARNING

Stored Energy Hazard: The lift mechanism in the tower is under tension and will move up rapidly, on its own, as soon as attached equipment is removed. For this reason, DO NOT remove equipment or make adjustments to lift tension unless the front assembly has been moved to the highest position on the tower! Failure to follow this instruction may result in serious personal injury and/or equipment damage!

ADVERTENCIA

Riesgo de energía almacenada: El mecanismo de elevación de la torre está bajo tensión y se moverá rápidamente hacia arriba por sí solo si se retira el equipamiento que hay conectado al mismo. Es por ello que NO deberá quitar equipamiento ni hacer ajustes en la tensión de elevación a menos que la estructura delantera se haya movido antes hacia la posición más alta de la torre. No seguir estas instrucciones podría provocar daños personales y/o materiales graves.

AVERTISSEMENT

Danger : Le mécanisme d'élévation dans la tour est sous tension et se lève rapidement, tout seul, dès que le matériel est retiré. Pour cette raison, NE PAS retirer votre matériel ou faire des ajustements à la tension d'élévation à moins que la partie avant n'ait été mise à la position la plus élevée de la tour ! Risque de blessure corporelle ou d'endommagement matériel en cas de non respect de cette instruction.

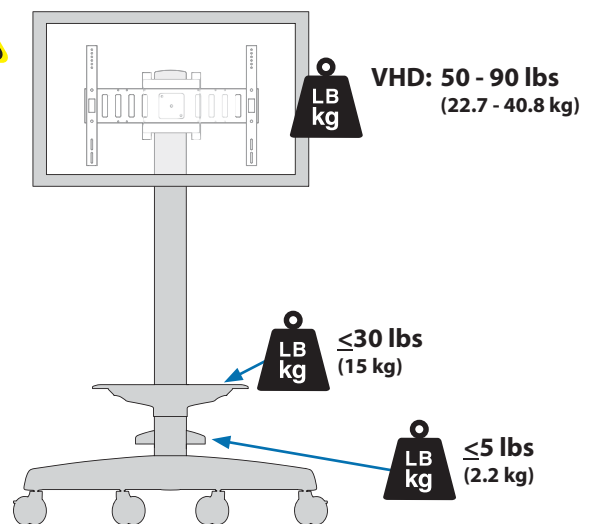
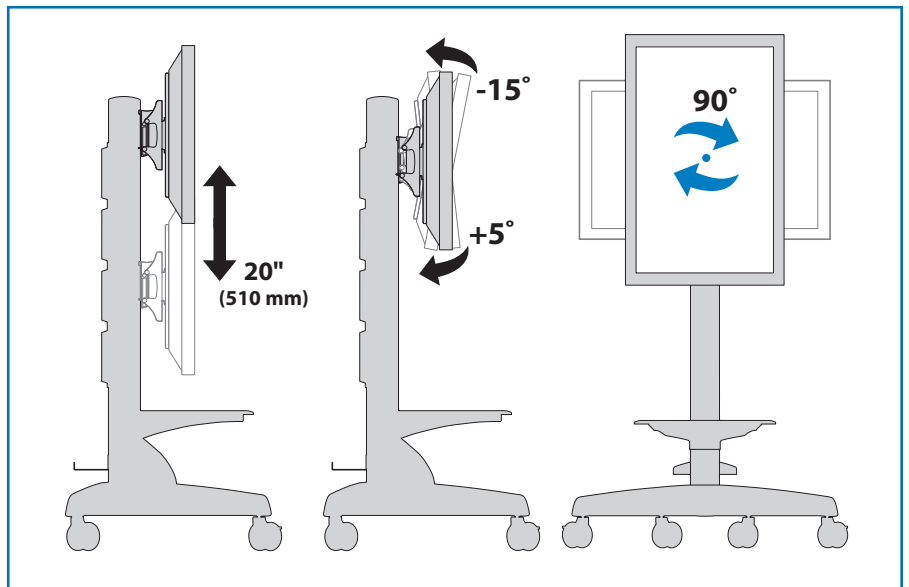

For service and warranty visit www.ergotron.com
 Si desea información de servicio y garantía, visite www.ergotron.com
 Pour toute question concernant la garantie ou le service client, consultez www.ergotron.com
 Weitere Informationen zu Service und Gewährleistung erhalten Sie unter www.ergotron.com.
 Ga voor service en garantie naar www.ergotron.com
 Per assistenza e la garanzia visitare www.ergotron.com
 Gå in på www.ergotron.com för service och garanti
 サービスおよび保証について詳しくは、www.ergotron.com をご覧ください。
 有关服务和保修，请访问 www.ergotron.com

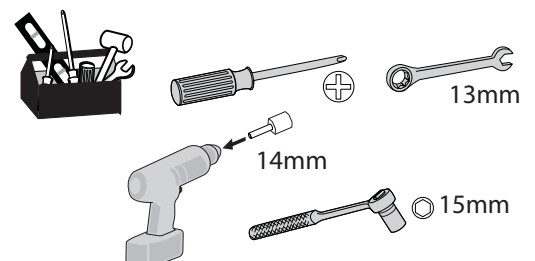



	A	B
1		Leg Mounting Hardware 4x M10 x 60mm 4x
2		Leg Cover Mounting Screws 8x M3.5 x 6mm
3		Shelf Mounting Hardware 8x 4x M3 x 37mm 2x
4		TM Mounting Hardware 4x M6x8mm 2x 4x 4x M8 x 14mm 1x 2x M4 x 16mm
5		400mm Extension Hardware 4x 4x M5 x 16mm
6		Large Display Cart Hardware 4x M6x20mm 4x M6x45mm 4x M8x25mm 4x M8x50mm
7		100x100mm VESA Plate Hardware 4x M5 x 10mm
8		Power Strip Hardware 2x 2x M5x9mm
9		Cable Management Support Hardware 1x M5x8mm 1x 2x
10		Top Cap Hardware 1x 1x M5x8mm

1 a

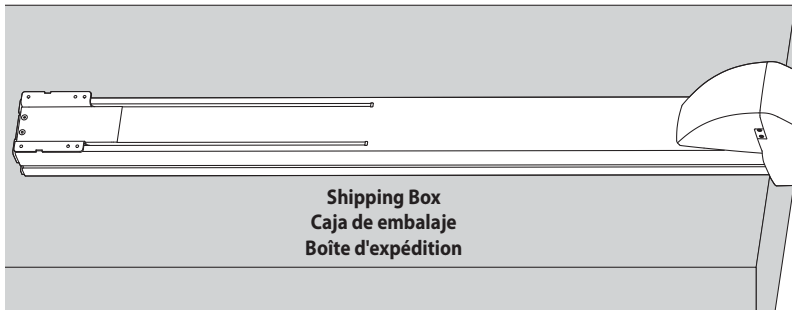
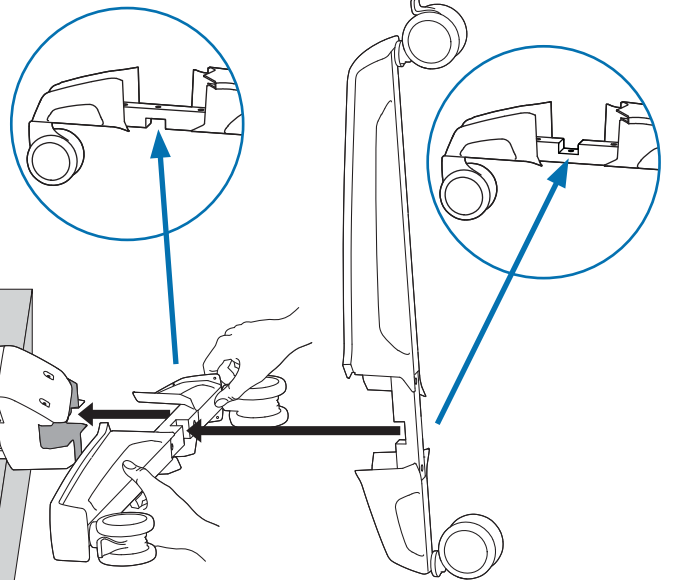
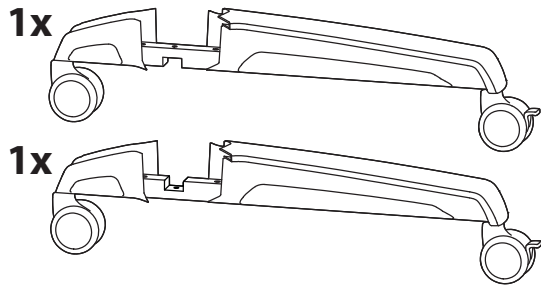

Shipping Box
Caja de embalaje
Boîte d'expédition

b

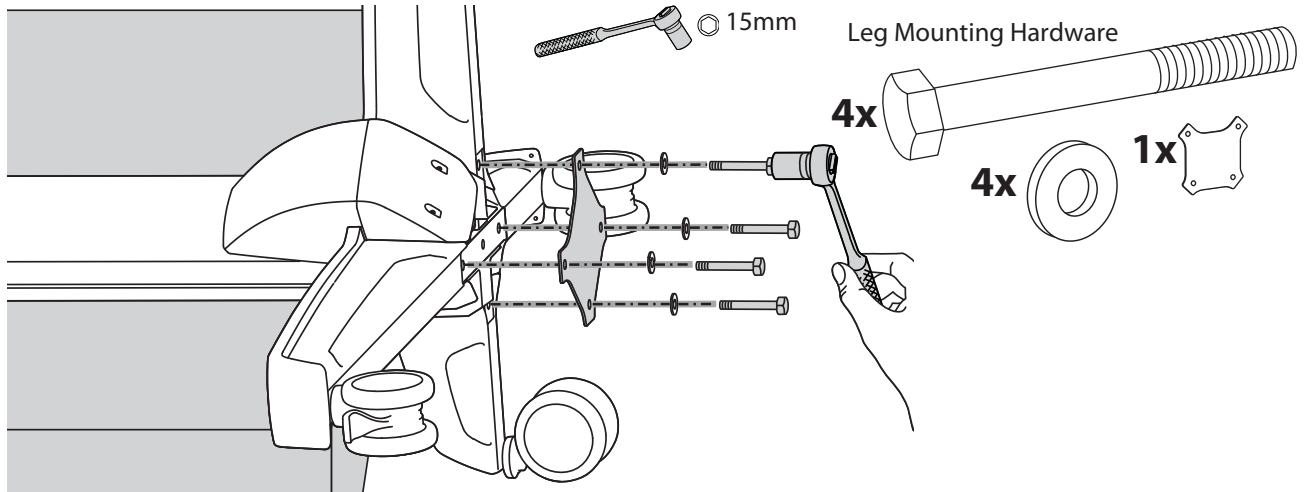

2

Leg Cover Mounting Screws

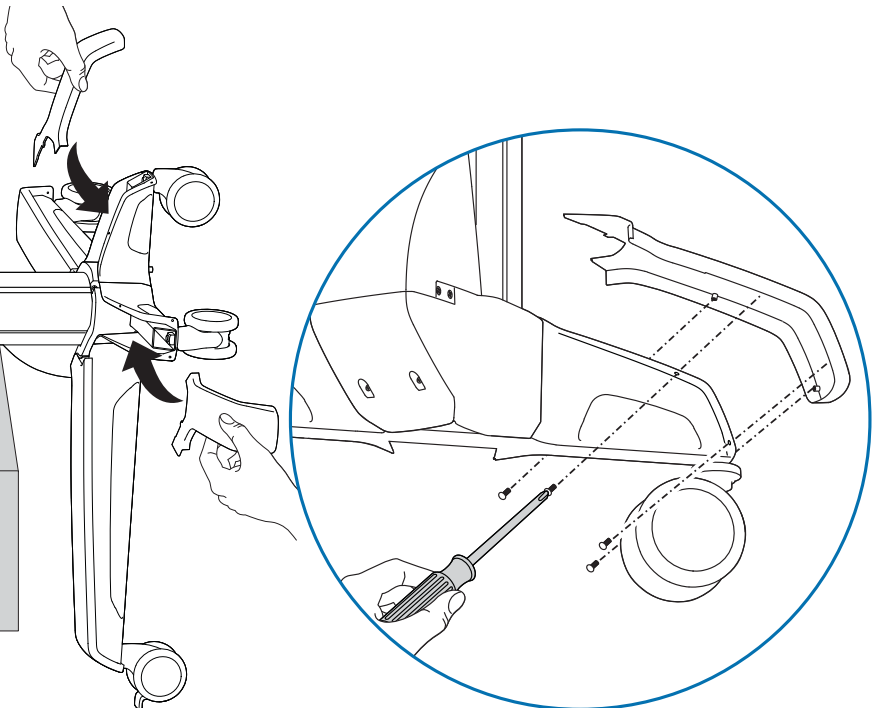

CAUTION: DO NOT overtighten fasteners. Overtightening may cause damage to your equipment.
Cuidado: No sobreapriete los tornillos, pues podría causar un daño al equipo.
Attention: ne forcez pas le serrage de la vis, cela pourrait endommager l'écran et/ou les attaches.

3 a

Shelf Mounting Hardware

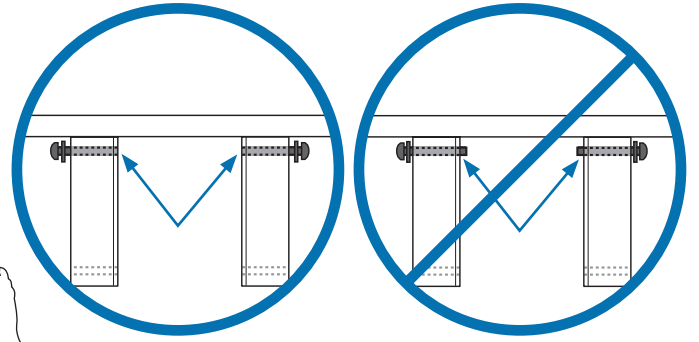
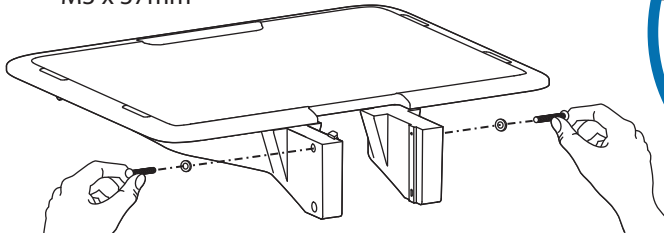
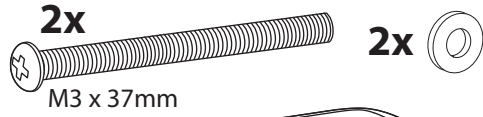

b

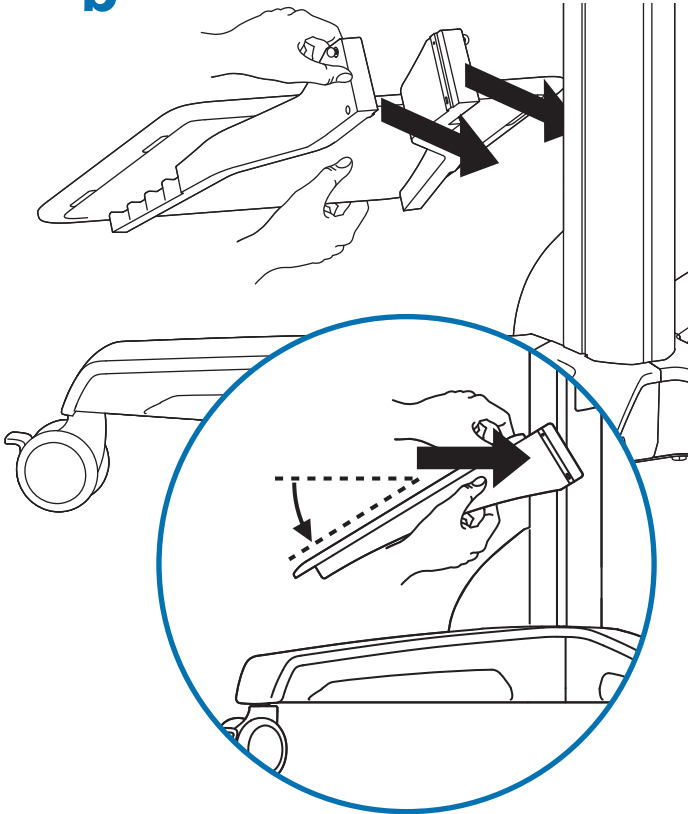

c

Shelf Mounting Hardware

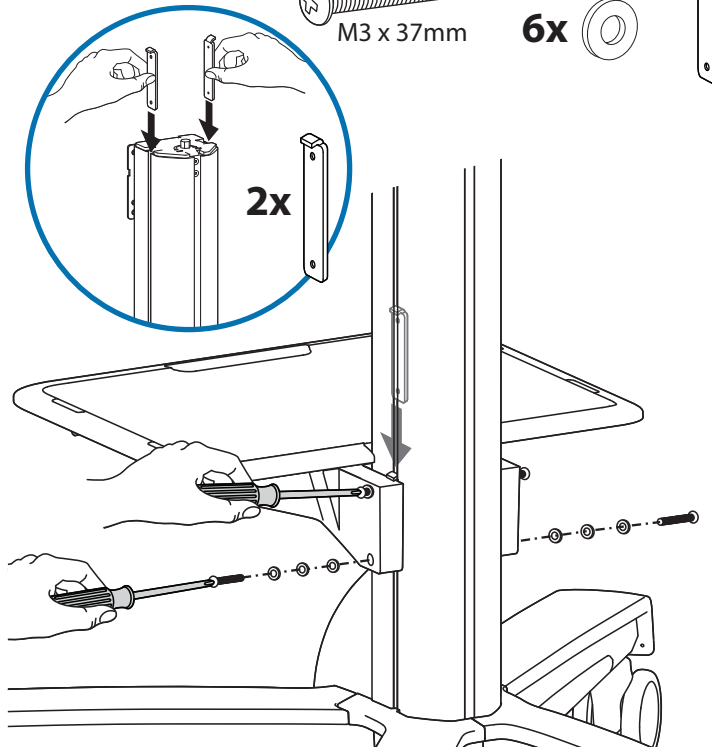
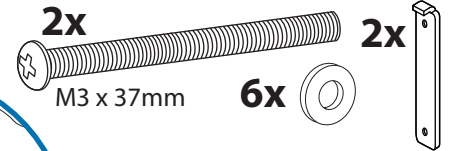

4 a

TM Mounting Hardware

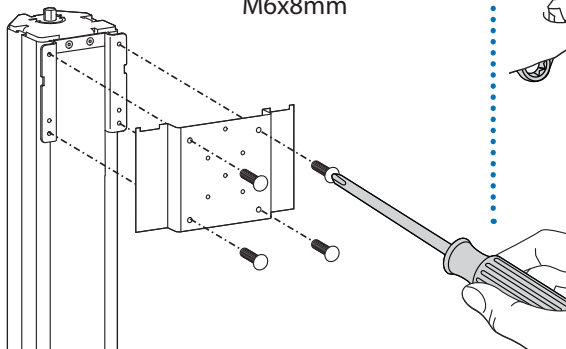

b

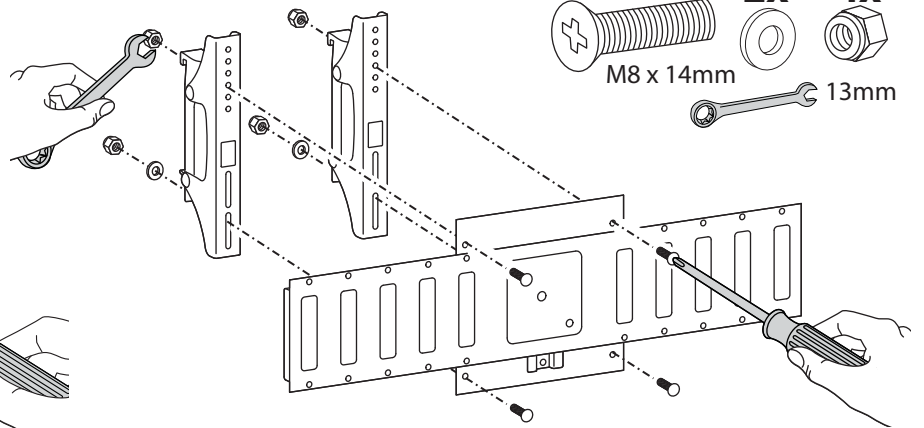

5

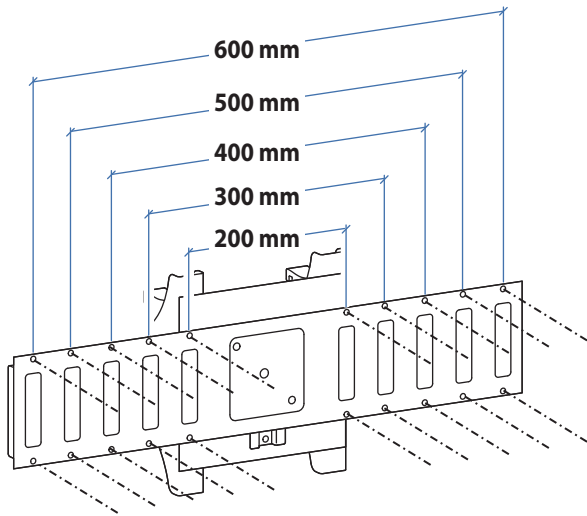
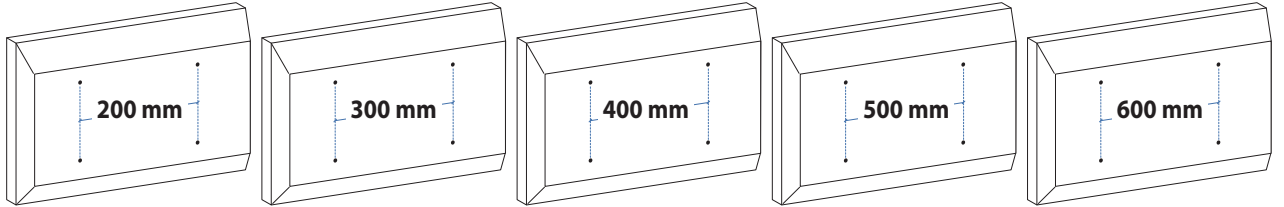
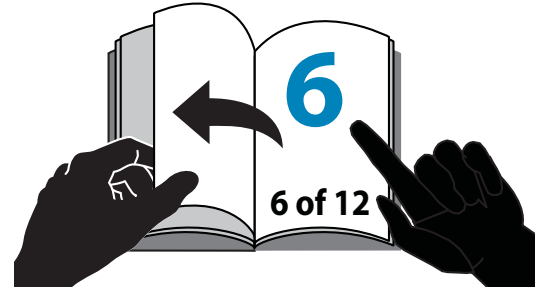
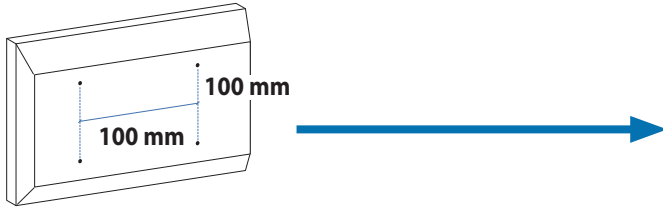

400mm Extension Hardware

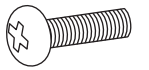
4x 

M5 x 16mm

4x 

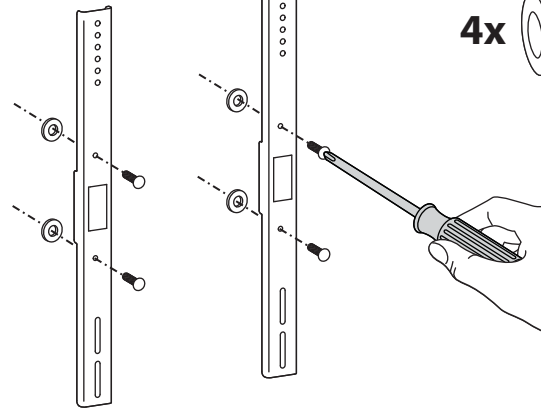

6

FIND APPROPRIATE FASTENERS FOR YOUR DISPLAY: BUSQUE ABRAZADERAS APROPIADAS PARA LA PANTALLA: TROUVEZ LES FIXATIONS APPROPRIÉES À VOTRE ÉCRAN :

Large Display Cart Hardware

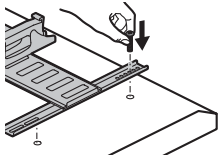
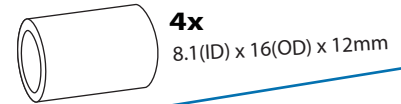
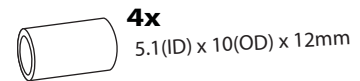
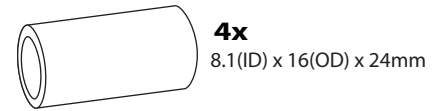
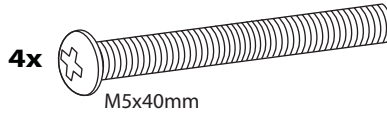
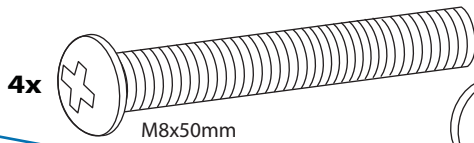
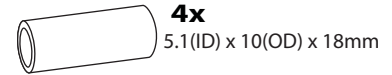
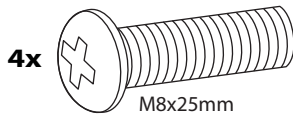
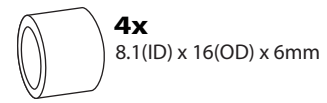
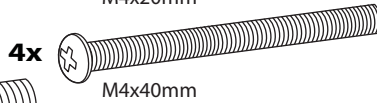
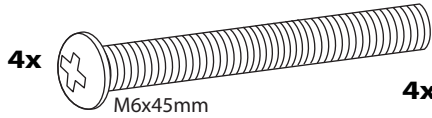
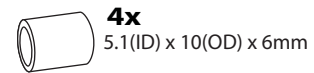
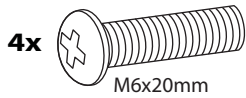

Screw Diameter
Diámetro de tornillo
Diamètre de vis

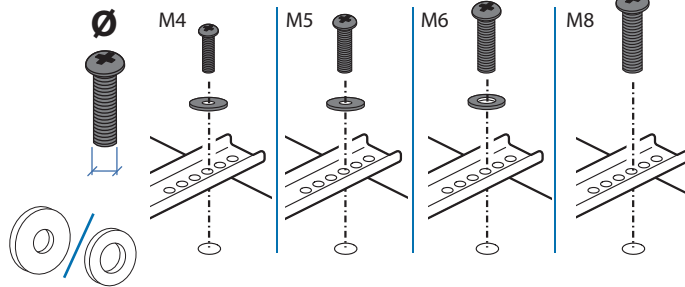

Screw Length
Longitud de tornillo
Longueur de vis

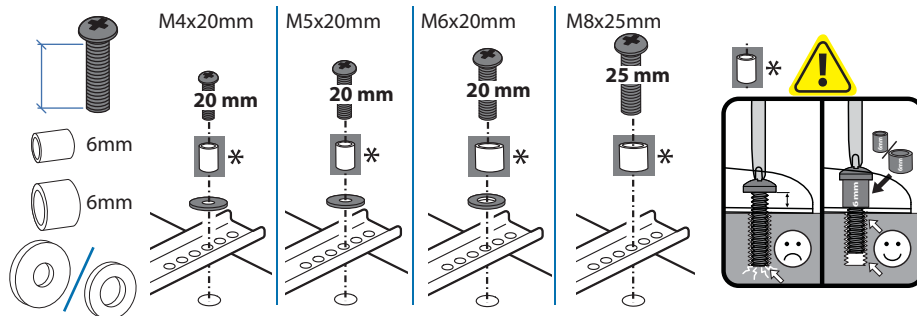

IMPORTANT: To ensure screws have the minimum thread engagement in the display, tighten screws with at least six, full, 360° revolutions.
IMPORTANTE: Para asegurarse de que los tornillos tienen la mínima capturada la rosca mínima necesaria en la pantalla, apriételos con al menos seis vueltas de rosca completas (de 360°).
IMPORTANT : afin de vous assurer que les vis sont bien engagées dans l'écran, serrez-les en effectuant au moins six tours complets de 360°.

CAUTION: DO NOT overtighten fasteners. Overtightening may cause damage to your equipment.
Cuidado:: No sobreapriete los tornillos, pues podría causar un daño al equipo.
Attention: ne forcez pas le serrage de la vis, cela pourrait endommager l'écran et/ou les attaches.

Recessed Mount
Empotrado
Encastré

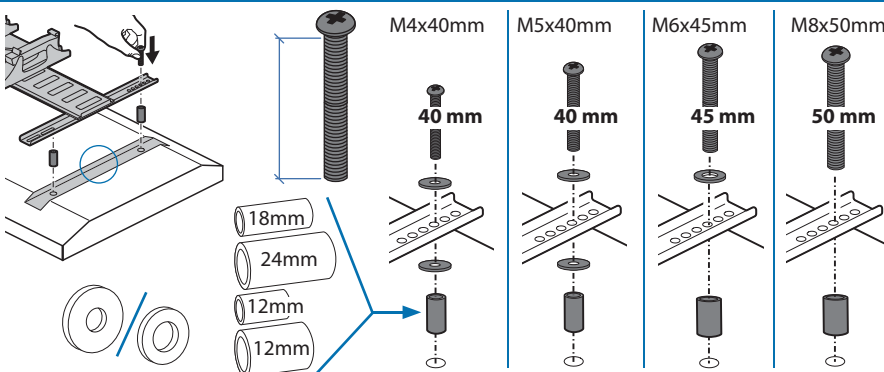

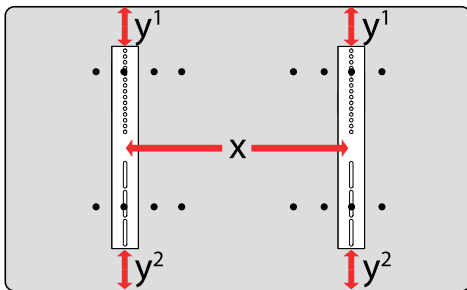
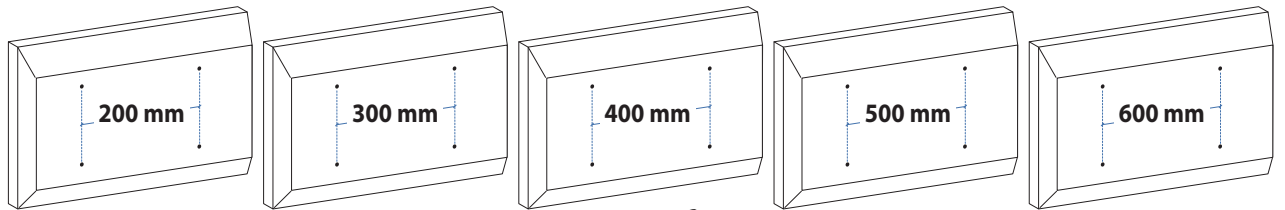
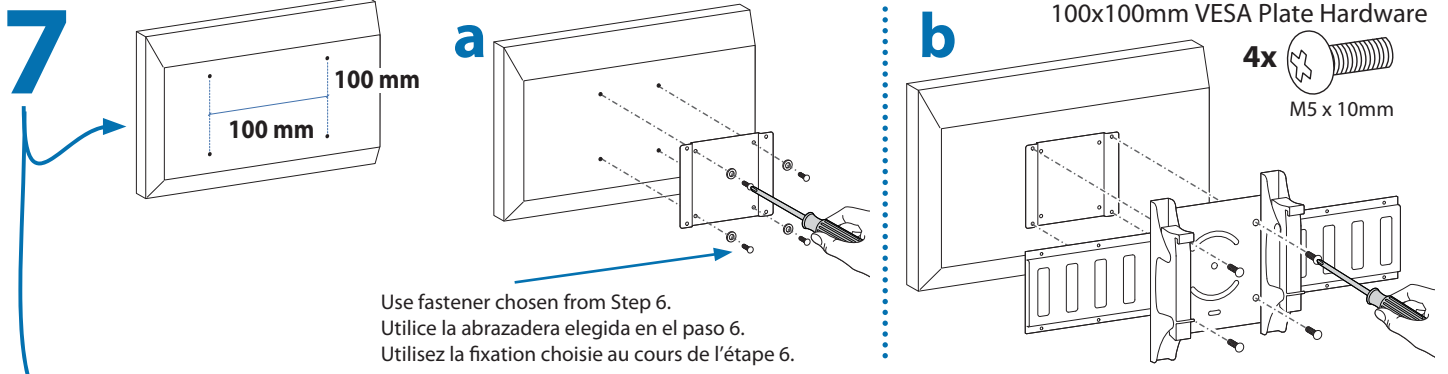

$y^1 = y^2$
 $x \leq 600\text{mm}$

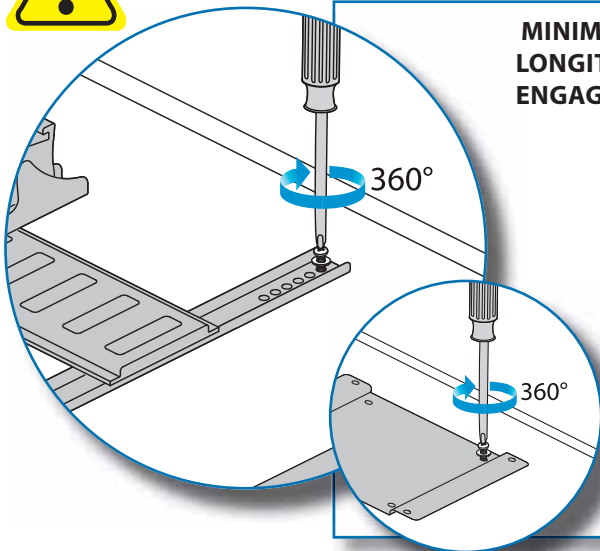
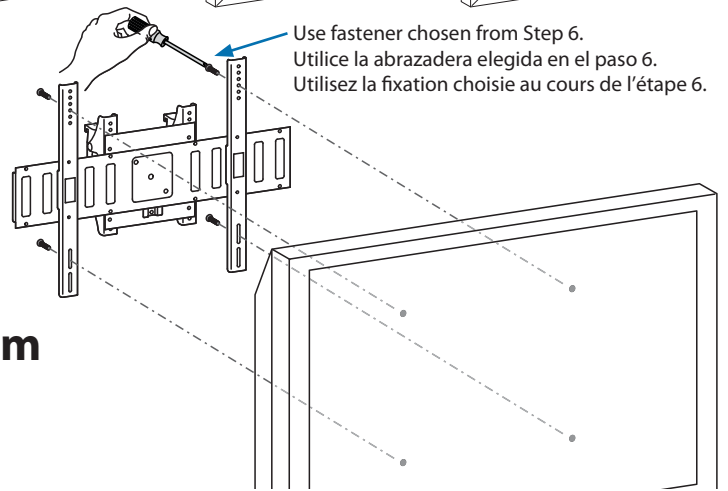

**MINIMUM THREAD ENGAGEMENT
LONGITUD MÍNIMA A ENROSCAR
ENGAGEMENT MINIMUM DES VIS**

4mm	4		
5mm	5		
6mm	6		
8mm	8		

g Tighten screws with at least six, full, 360° revolutions*, but do not over tighten; over tightening may cause damage to display and/or brackets.

* Six full turns will ensure a minimum thread engagement roughly equal to the diameter of the screw. For instance, if the screw diameter is 8mm, the minimum thread engagement is also 8mm.)

g Apriete los tornillos con al menos 6 giros completos de 360°*, pero no los sobreapriete pues podría dañar el monitor y/o los soportes de montaje.

* Seis giros completos aseguran una rosca mínima del tornillo prácticamente igual al diámetro del tornillo. Por ejemplo, si el diámetro del tornillo es de 8 mm., la rosca mínima deberá ser también de 8 mm.

g Serrez la vis en réalisant au moins 6 tours complets* de 360°. Ne serrez pas trop car cela pourrait endommager l'écran et/ou les étriers.

* 6 tours complets permettent d'engager la vis d'à peu près la longueur de son diamètre. Par exemple, si la vis a pour diamètre 8mm, la longueur engagée sera également de 8 mm.

8

a

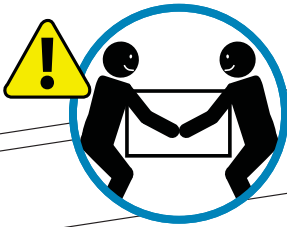

b

TM Mounting Hardware

2x  M4 x 16mm

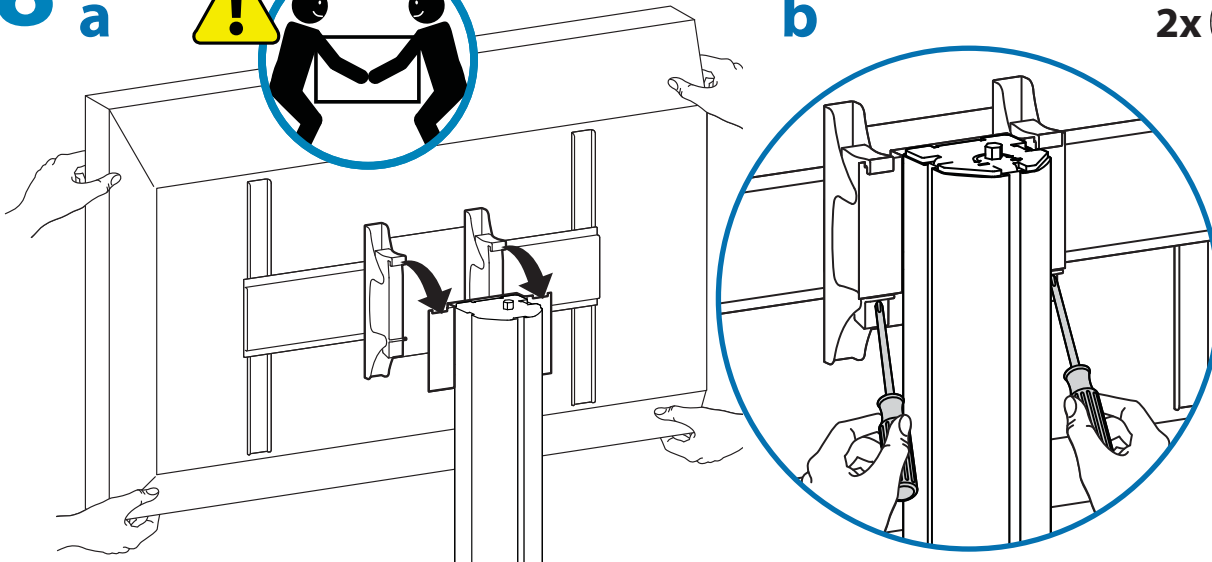

9

It is important that you adjust this product according to the weight of the mounted equipment as described in the following steps. Any time equipment is added or removed from this product, resulting in a change in the weight of the mounted load, you should repeat these adjustment steps to ensure safe and optimum operation.

Adjustments should move smoothly and easily through the full range of motion and stay where you set it. If adjustments are difficult and do not stay in the desired position, follow the instructions to loosen or tighten the tension to create a smooth, easy adjustment motion. Depending on your product and the adjustment, it may take several turns to notice a difference.

Es importante ajustar este producto conforme al peso del equipo montado, según se describe en los pasos siguientes. Cada vez que se agregue o quite equipo de este producto y cambie el peso de la carga montada, deberá repetir estos ajustes para garantizar un funcionamiento seguro y óptimo.

Los movimientos de ajuste deben poder realizarse de manera suave y firme dentro de la amplitud de movimiento permitida, y mantenerse donde usted los fije. Si los ajustes son abruptos o no permanecen en dicha posición, siga las instrucciones para aflojar o ajustar la tensión y suavizar así el movimiento. Dependiendo del producto y el ajuste, es posible que deba hacer varios intentos hasta poder observar la diferencia.

Il est important que vous fixiez ce produit par rapport au poids du matériel installé, comme l'indiquent les étapes suivantes. À chaque fois que vous ajoutez ou que vous retirez du matériel de ce produit, et que le poids du matériel change, répétez ces étapes d'ajustement pour garantir la sécurité et une utilisation optimale.

Les réglages doivent s'effectuer facilement et sans forcer dans toutes les positions et rester en place une fois réalisés. Si les réglages sont difficiles à effectuer et ne restent pas en position, suivez les instructions pour desserrer ou resserrer la tension afin que les mouvements soient plus aisés. Selon le produit que vous utilisez et le réglage, il faut parfois effectuer plusieurs tours de vis avant de remarquer une différence.

Lift – Up and down
Elevación (arriba y abajo)
Ajustement en hauteur : bas et haut

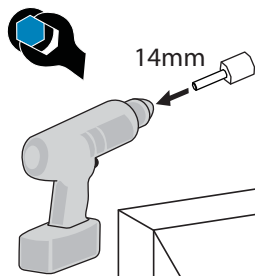
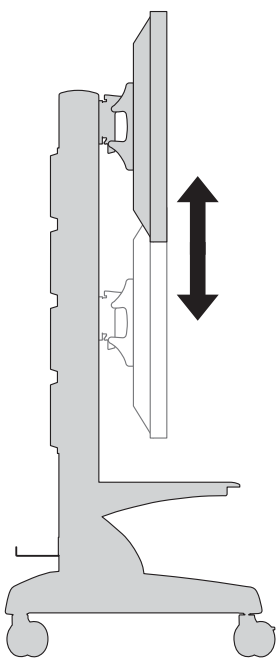

Follow these instructions to tighten or loosen tension.
 Siga estas instrucciones para ajustar o aflojar la tensión.
 Suivez ces instructions pour desserrer ou resserrer la tension.

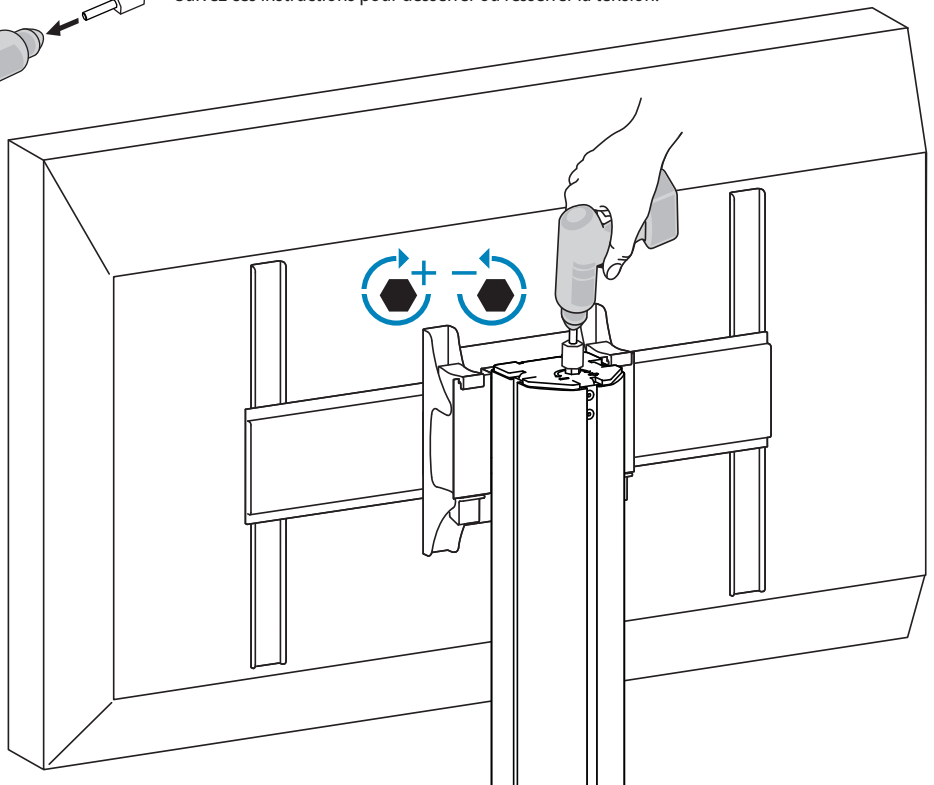

10

TM Mounting Hardware

1x 

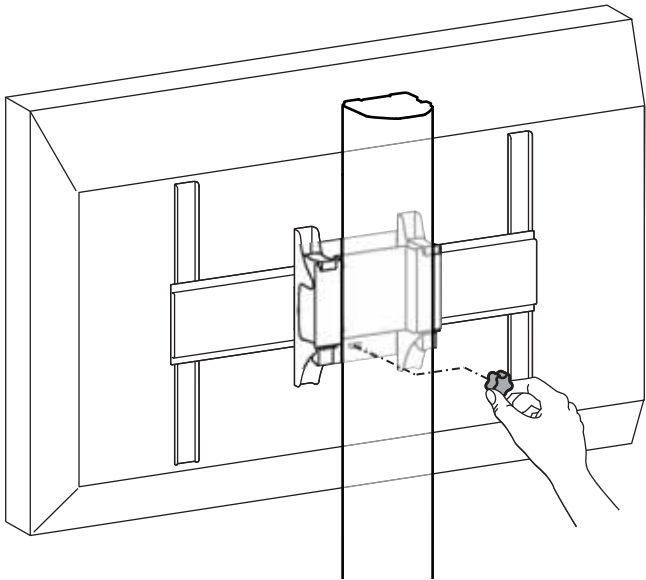
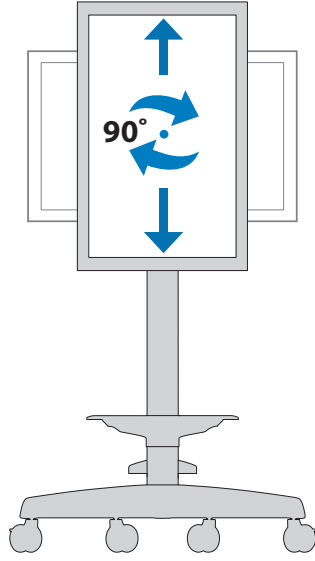
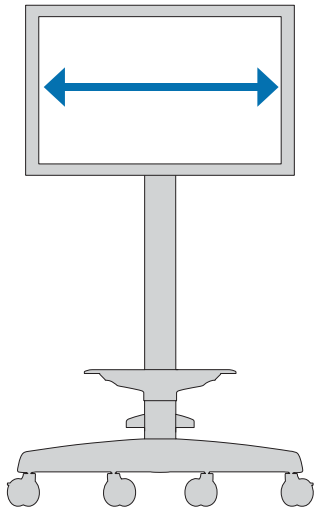

a

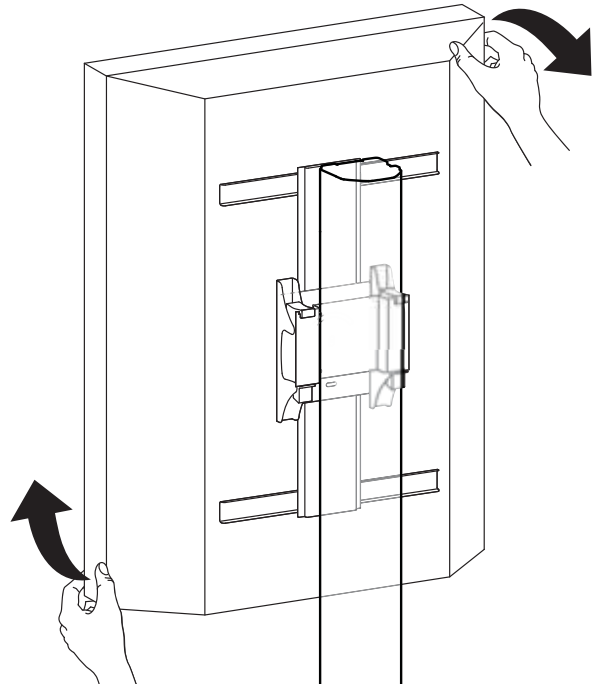

b

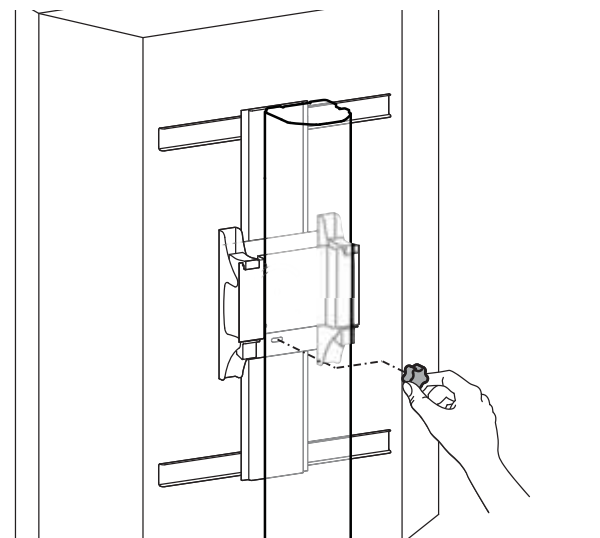

11a

Power Strip Hardware

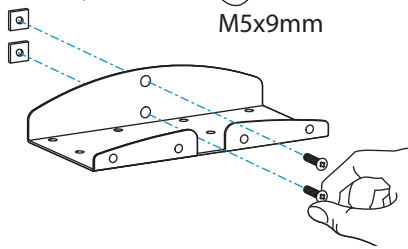
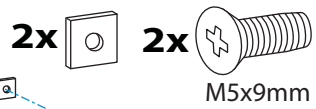

b

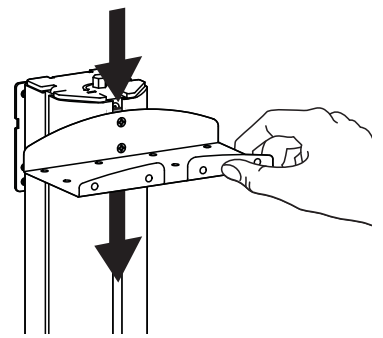

c

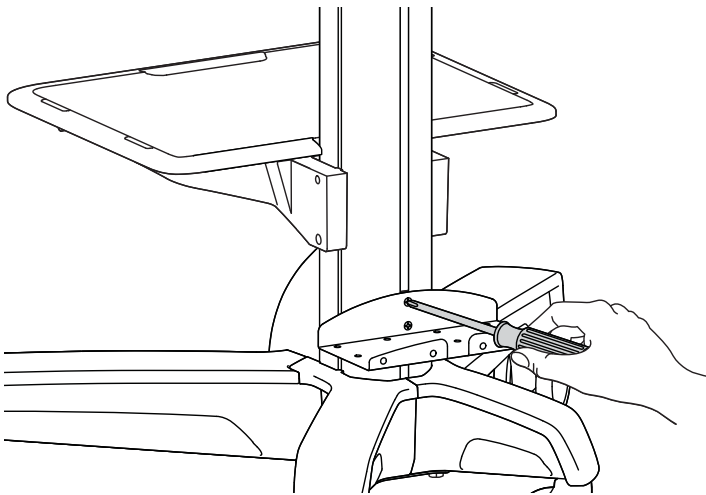

Cable Management Support Hardware



d

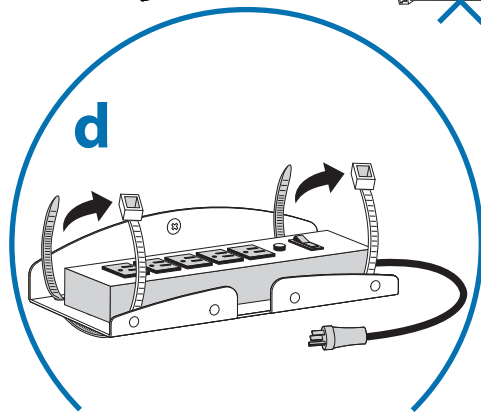

12

a

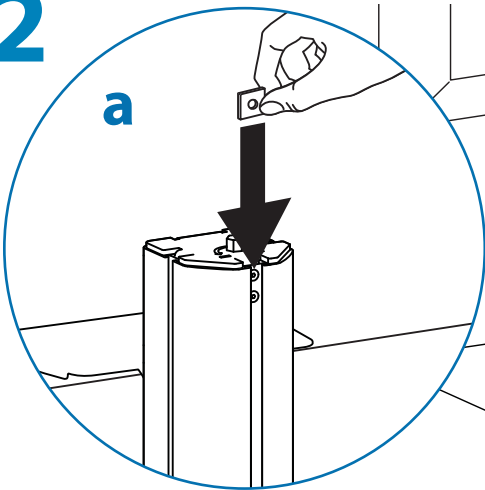

b

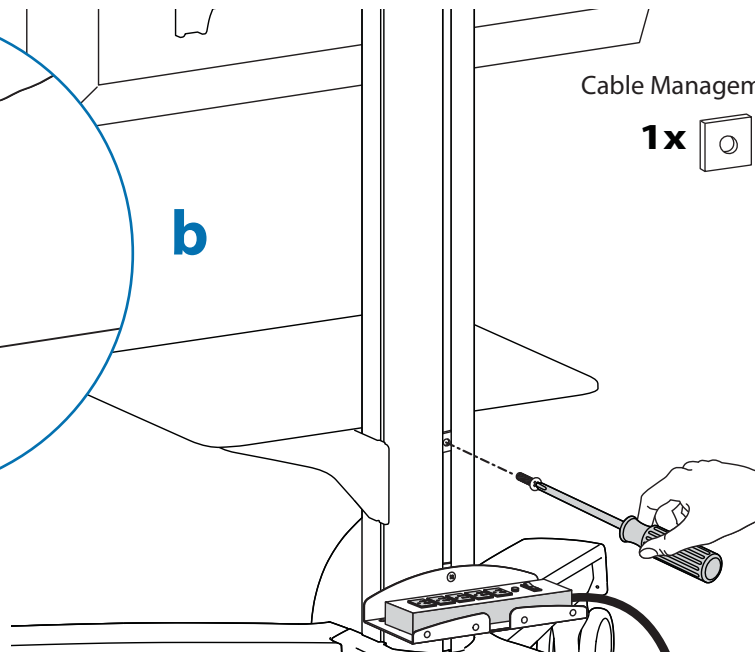

Cable Management Support Hardware

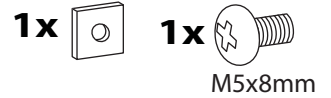

C

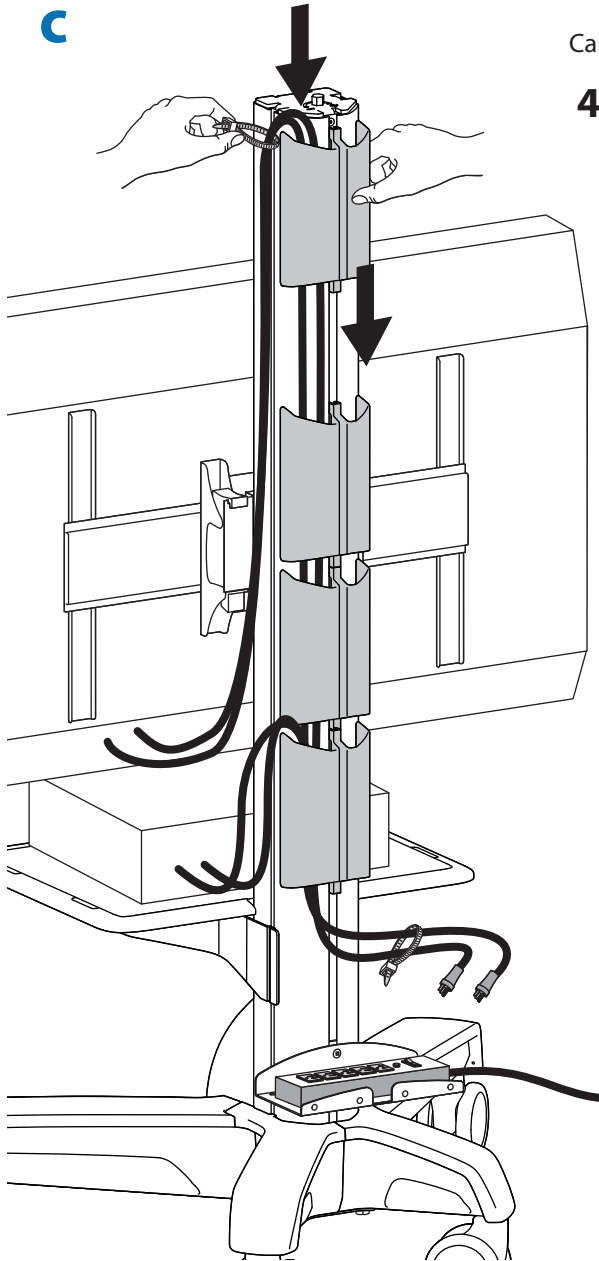

Cable Management Support Hardware



NOTE: Leave enough slack in cables to allow full range of motion.

No deje el cable excesivamente tenso

Laissez du mou dans le câble

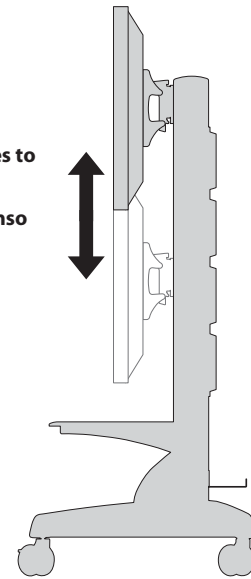

d

Top Cap Hardware

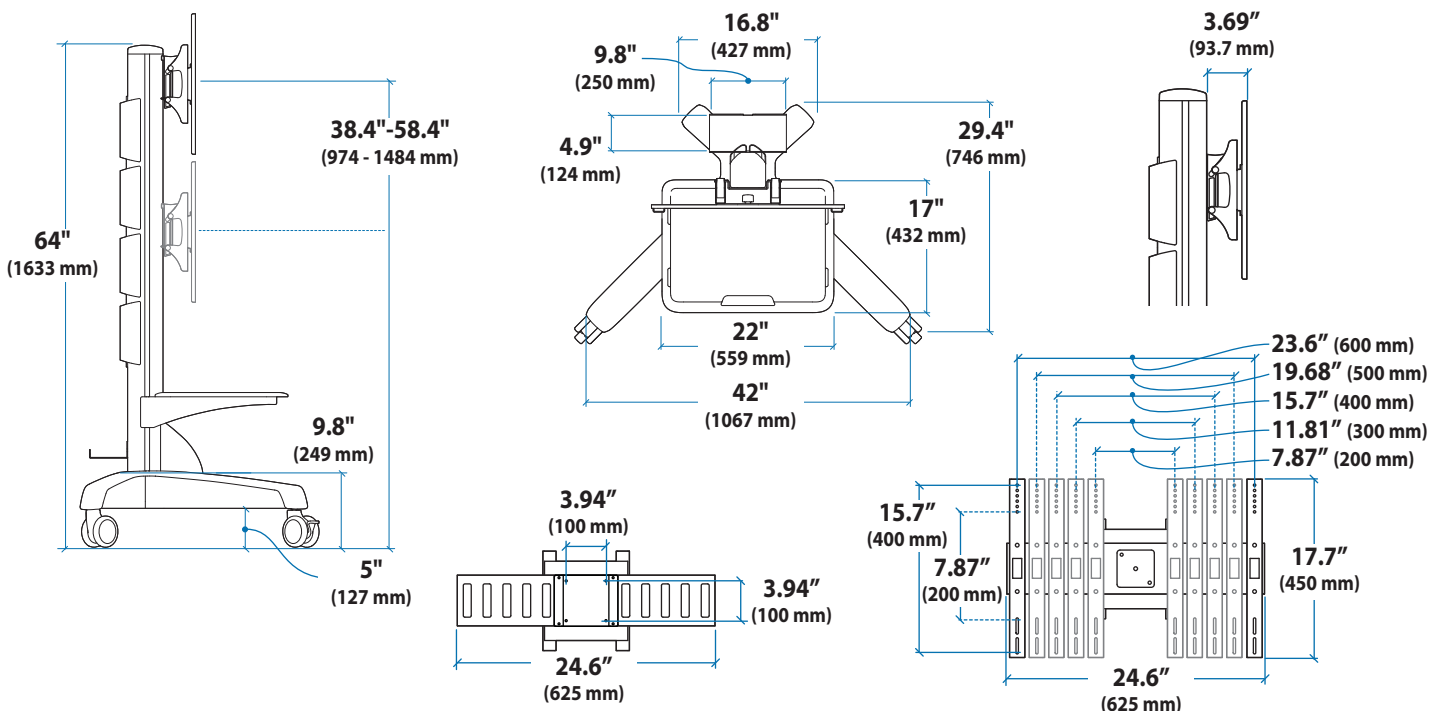
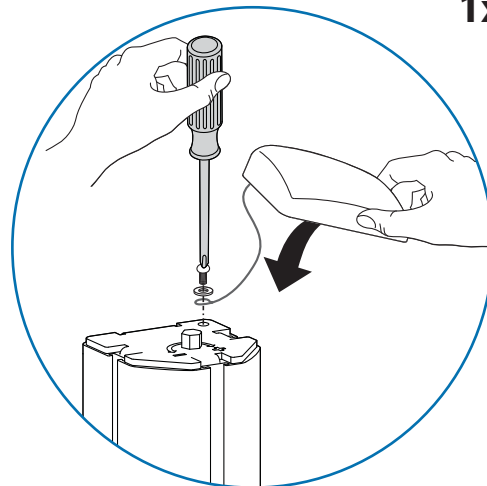
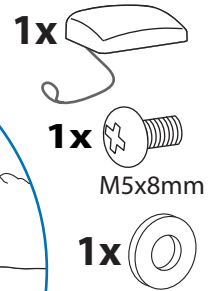

⚠ WARNING

STORED ENERGY HAZARD! DO NOT OPEN TOWER OR REMOVE SAFETY GUARD!

A primary mechanism within the tower is under tension and can be hazardous to people exposed to it under certain extreme conditions. DO NOT open the tower; DO NOT attempt to service the cart/stand. DO NOT remove safety guards or labels designed to protect or inform of possible hazards. Only Ergotron-approved installers may service or otherwise modify cart/stand. Failure to heed this Warning may result in serious Personal Injury and Damage both to the cart/stand and equipment.



⚠ WARNING

DO NOT load the Cart/Stand past maximum weight capacity. DO NOT mount a display larger than the recommended size. Failure to comply with warning may result in Cart/Stand instability leading to equipment damage or personal injury.



⚠ WARNING



TIPPING HAZARD!

DO NOT allow children on Cart / Stand. DO NOT route electric cords or equipment cables within reach of children. LOCK CASTERS when Cart is stationary. Failure to comply with this warning may result in Cart / Stand instability leading to equipment damage or personal injury.

⚠ CAUTION



TIPPING HAZARD!

DO NOT move Cart with Display in highest position. DO NOT push Cart from front or back of Tower. DO NOT move Cart over cords or uneven, dirty, soft or sloping surfaces. DO NOT move Cart by pushing on Display. Failure to comply with this caution may result in Cart instability leading to equipment damage or personal injury.

TO MOVE CART

1. Push Display down to lowest position on Cart.
2. Disconnect power cord and attach to Tower.
3. Unlock casters; point casters in direction of travel.
4. Push Cart from side with hands on Tower.

822-026-00

Americas Sales and Corporate Headquarters

St. Paul, MN USA
(800) 888-8458
+1-651-681-7600
www.ergotron.com
sales@ergotron.com

EMEA Sales

Amersfoort, The Netherlands
+31 33 45 45 600
www.ergotron.com
info.eu@ergotron.com

APAC Sales

Tokyo, Japan
www.ergotron.com
apaccustomerservice@ergotron.com

Worldwide OEM Sales

www.ergotron.com
info.oem@ergotron.com



© 2011 Ergotron, Inc.
All rights reserved.

While Ergotron, Inc. makes every effort to provide accurate and complete information on the installation and use of its products, it will not be held liable for any editorial errors or omissions (including those made in the process of translation from English to another language), or for incidental, special or consequential damages of any nature resulting from furnishing this instruction and performance of equipment in connection with this instruction. Ergotron, Inc. reserves the right to make changes in the product design and/or product documentation without notification to its users. For the most current product information, or to know if this document is available in languages other than those herein, please contact Ergotron. No part of this publication may be reproduced, stored in a retrieval system, or transmitted in any form or by any means, electronic, mechanical, photocopying, recording or otherwise without the prior written consent of Ergotron, Inc., 1181 Trapp Road, Eagan, Minnesota, 55121, USA. Patents Pending and Patented U.S. & Foreign. Ergotron is a registered trademark of Ergotron, Inc.

Neo-Flex Mobile Media Center, VHD with 90° Portrait/Landscape rotation

1

Leg Mounting Hardware

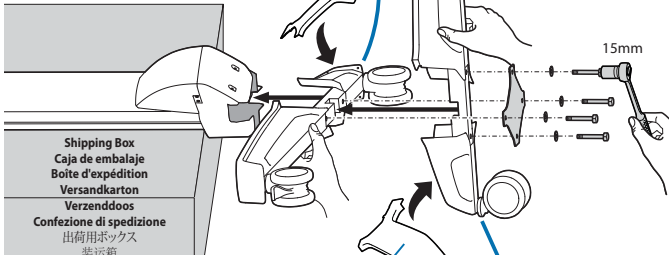
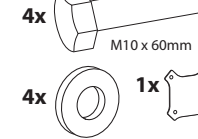

2

Leg Cover Mounting Screws



CAUTION: DO NOT overtighten fasteners. Overtightening may cause damage to your equipment.
Cuidado: No sobreapriete los tornillos, pues podría causar un daño al equipo.
Attention: ne forcez pas le serrage de la vis, cela pourrait endommager l'écran et/ou les attaches.
WARNUNG: Zu festes Anziehen der Schrauben kann zu Beschädigungen führen.
LET OP: draai de schroeven niet te strak aan. Te strak aandraaien kan schade veroorzaken aan uw apparaat.
ATTENZIONE: Non stringere eccessivamente i dispositivi di fissaggio. Ciò potrebbe causare danni all'apparecchiatura.
 注意: 調節ネジは締めすぎないようにしてください。強く締め 付けすぎると、器具が破損する原因となります。
 小心: 不要过度拧紧固定器。过度拧紧可能会损坏设备。
 주의: 고정 장치를 너무 세게 조이지 마십시오. 너무 세게 조이면 장비가 손상될 수 있습니다.

For service and warranty visit www.ergotron.com
 Si desea información de servicio y garantía, visite www.ergotron.com
 Pour toute question concernant la garantie ou le service client, consultez www.ergotron.com
 Weitere Informationen zu Service und Gewährleistung erhalten Sie unter www.ergotron.com.
 Ga voor service en garantie naar www.ergotron.com
 Per assistenza e la garanzia visitate www.ergotron.com
 Gå in på www.ergotron.com för service och garanti
 サービスおよび保証について詳しくは、www.ergotron.com をご覧ください。
 有关服务和保修，请访问 www.ergotron.com

For more information on this product or installation visit:

www.ergotron.com



User's Guide - English
 Guía del usuario - Español
 Manuel de l'utilisateur - Français
 Gebruikersgids - Nederlands
 Benutzerhandbuch - Deutsch
 Guida per l'utente - Italiano
 ユーザーガイド - 日本語
 用户指南 - 汉语
 사용자 안내서 - 韓国

www.ergotron.com
 USA 1-800-888-8458
 Europe +31 (0)33-45 45 600
 China 86-769-86018920

Americas Sales and Corporate Headquarters
 St. Paul, MN USA
 (800) 888-8458
 +1-651-681-7600
www.ergotron.com
sales@ergotron.com

EMEA Sales
 Amersfoort, The Netherlands
 +31 33 45 45 600
www.ergotron.com
info.eu@ergotron.com

APAC Sales
 Tokyo, Japan
www.ergotron.com
apaccustomerservice@ergotron.com

Worldwide OEM Sales
www.ergotron.com
info.oem@ergotron.com

© 2011 Ergotron, Inc.
 All rights reserved.

While Ergotron, Inc. makes every effort to provide accurate and complete information on the installation and use of its products, it will not be held liable for any editorial errors or omissions (including those made in the process of translation from English to another language), or for incidental, special or consequential damages of any nature resulting from furnishing this instruction and performance of equipment in connection with this instruction. Ergotron, Inc. reserves the right to make changes in the product design and/or product documentation without notification to its users. For the most current product information, or to know if this document is available in languages other than those herein, please contact Ergotron. No part of this publication may be reproduced, stored in a retrieval system, or transmitted in any form or by any means, electronic, mechanical, photocopying, recording or otherwise without the prior written consent of Ergotron, Inc. 1181 Trapp Road, Eagan, Minnesota, 55121, USA
 Patents Pending and Patented U.S. & Foreign. Ergotron is a registered trademark of Ergotron, Inc.

3

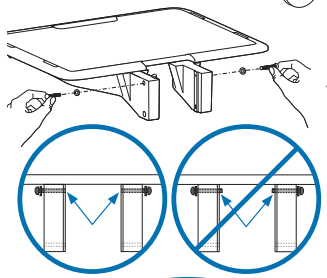
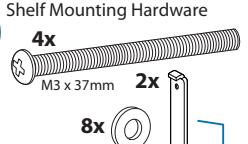

6

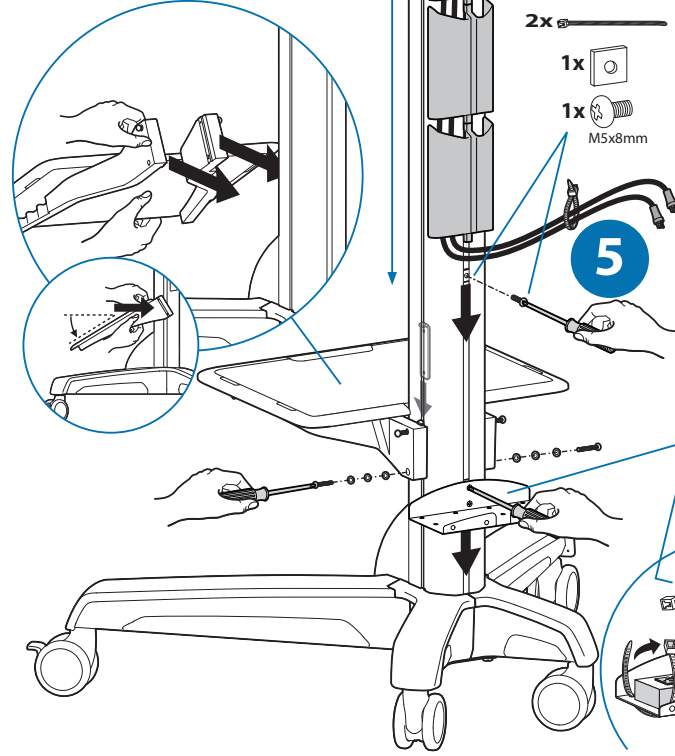

7

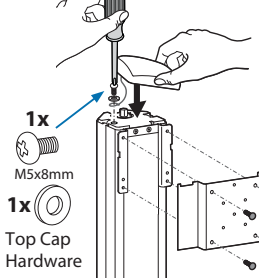

8

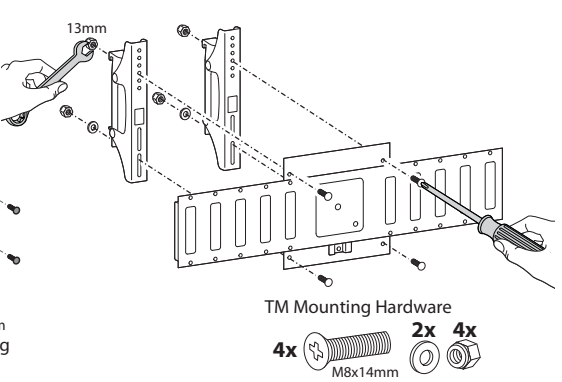

Cable Management Support Hardware

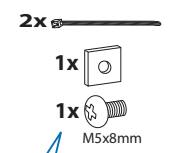

5

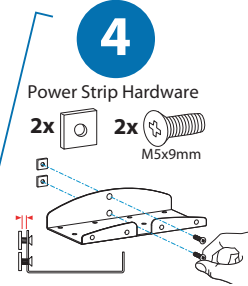

4

Power Strip Hardware

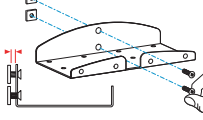

2x

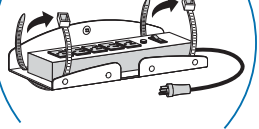

9

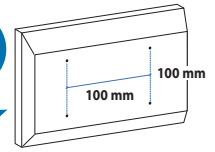

See step 10 on other side.

10

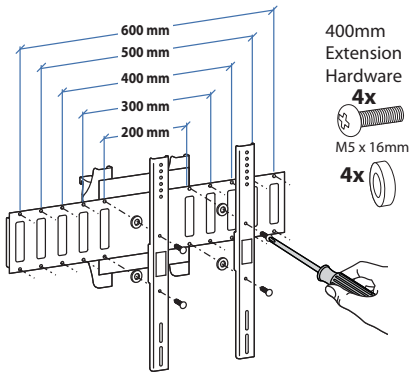
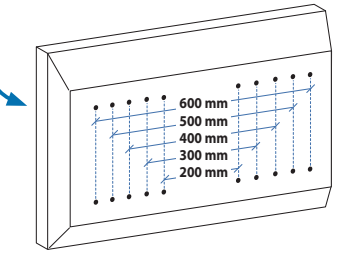

400mm Extension Hardware
4x
 M5 x 16mm
4x

10

FIND APPROPRIATE FASTENERS FOR YOUR DISPLAY:
BUSQUE ABRAZADERAS APROPIADAS PARA LA PANTALLA:
TROUVEZ LES FIXATIONS APPROPRIÉES À VOTRE ÉCRAN:
ERMITTLUNG ANGEMESSENER MONTAGETEILE FÜR IHREN BILDSCHIRM:
ZORG VOOR ADEQUATE BEVESTIGINGSMATERIALEN VOOR UW DISPLAYMODEL:
INDIVIDUARE LA VITERIA ADATTA PER IL DISPLAY:
 ディスプレイ用に適切なファスナーを見つける
 为显示器找到合适的紧固件:

Large Display Cart Hardware

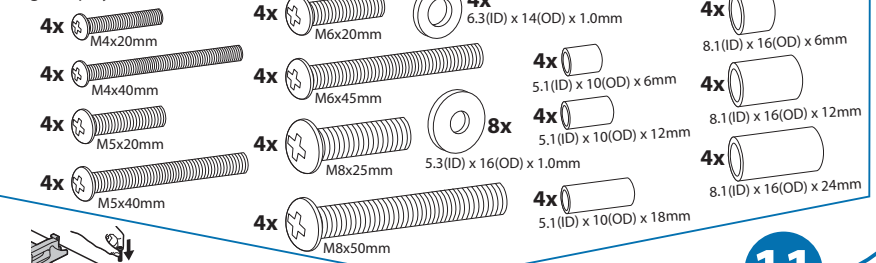

11

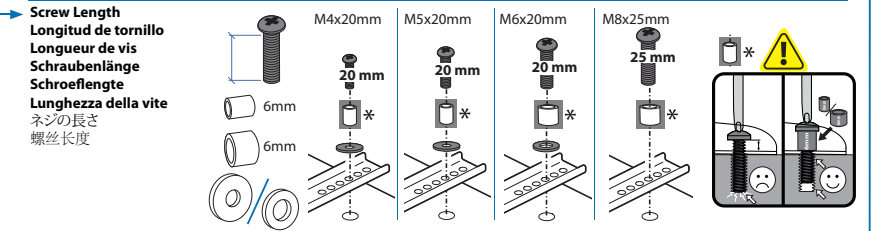
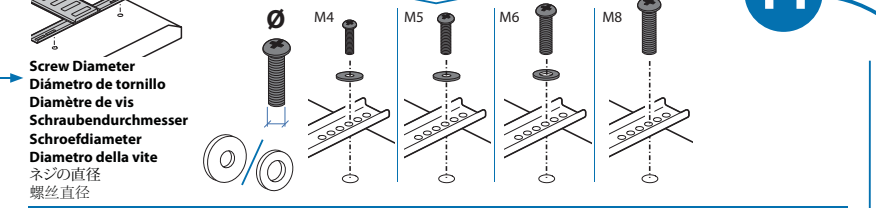

IMPORTANT: To ensure screws have the minimum thread engagement in the display, tighten screws with at least six full, 360° revolutions.
CAUTION: DO NOT overtighten fasteners. Overtightening may cause damage to your equipment.

IMPORTANTE: Para asegurarse de que los tornillos tienen capturada la rosca mínima necesaria en la pantalla, apriételos con al menos seis vueltas de rosca completas (de 360°).
Cuidado: No sobreapriete los tornillos, pues podría causar un daño al equipo.

IMPORTANT: afin de vous assurer que les vis sont bien engagées dans l'écran, serrez-les en effectuant au moins six tours complets de 360°.
Attention: ne forcez pas le serrage de la vis, cela pourrait endommager l'écran et/ou les attaches.

WICHTIG: Um sicherzustellen, dass die Schrauben über die minimale Gewindegängigkeit für den Bildschirm verfügen, ziehen Sie diese mit mindestens sechs vollen 360-Grad-Umdrehungen an. **WARNUNG: Zu festes Anziehen der Schrauben kann zu Beschädigungen führen.**

BELANGRIJK: Om ervoor te zorgen dat de schroeven voldoende ver in de display zijn gedraaid, moet u de schroeven vastzetten met minimaal zes volledige slagen (van 360°).
LET OP: draai de schroeven niet te strak aan. Te strak aandraaien kan schade veroorzaken aan uw apparatuur.

NOTA BENE: per far sì che le viti siano inserite nel display per la lunghezza minima di filettatura, avitarle per almeno sei giri completi.
ATTENZIONE: Non stringere eccessivamente i dispositivi di fissaggio. Ciò potrebbe causare danni all'apparecchiatura.

重要: ディスプレイのネジかみ合いを最小限度に抑えるため、ネジは少なくとも6回、360°回転させ、きつく締めてください。
 注意: 過剰ネジは締めすぎないようにしてください。強く締め付けすぎると、器具が破損する原因となります。
重要说明: 为确保螺丝在显示器中的螺纹啮合量最少, 拧螺丝时应至少转六满圈。
小心: 不要过度拧紧固定器。过度拧紧可能会损坏设备。

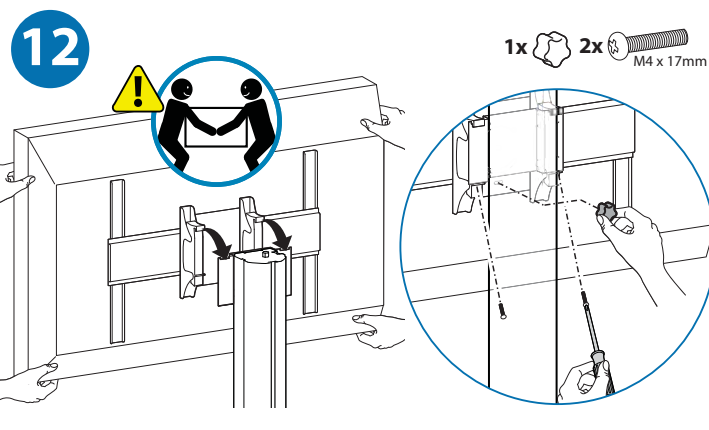
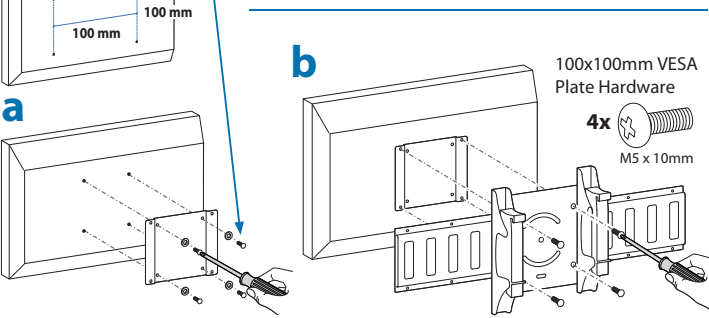
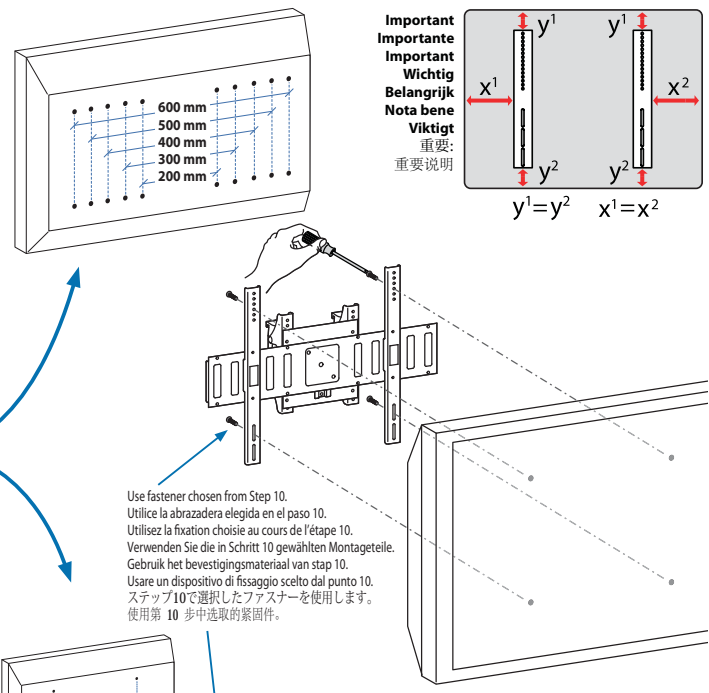
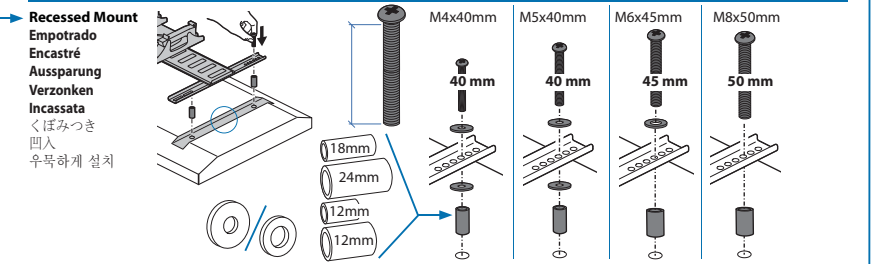

13

Adjustment
Ajuste
Réglage
Einstellung
Regolazione
調整
조절

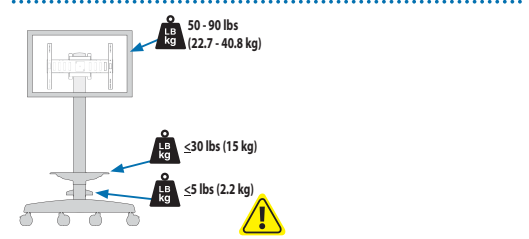
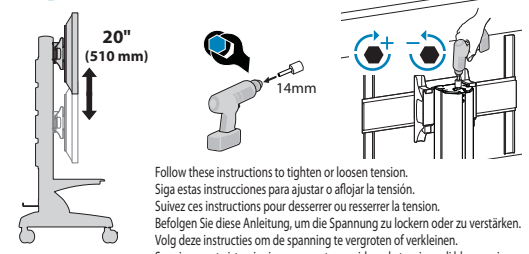

WARNING: Stored Energy Hazard: The lift mechanism in the tower is under tension and will move up rapidly on its own, as soon as attached equipment is removed. For this reason, DO NOT remove equipment or make adjustments to lift tension unless the front assembly has been moved to the highest position on the tower! Failure to follow this instruction may result in serious personal injury and/or equipment damage!

ADVERTENCIA: Riesgo de energía almacenada: El mecanismo de elevación de la torre está bajo tensión y se moverá rápidamente hacia arriba por sí solo si se retira el equipamiento que hay conectado al mismo. Es por ello que NO deberá quitar equipamiento ni hacer ajustes en la tensión de elevación a menos que la estructura delantera se haya movido antes hacia la posición más alta de la torre. No seguir estas instrucciones podría provocar daños personales y/o materiales graves.

AVERTISSEMENT: Danger : Le mécanisme d'élevation dans la tour est sous tension et se lève rapidement, tout seul, dès que le matériel est retiré. Pour cette raison, NE PAS retirer votre matériel ou faire des ajustements à la tension d'élevation à moins que la partie avant n'ait été mise à la position la plus élevée de la tour ! Risque de blessure corporelle ou d'endommagement matériel en cas de non respect de cette instruction.

WARNING: Gefährdung durch gespeicherte Energie: Der Lift-Mechanismus im Turm steht unter Spannung und bewegt sich aus eigenem Antrieb schnell nach oben, sobald das befestigte Zubehör entfernt wird. Aus diesem Grund darf das Zubehör NICHT ENTFERNT WERDEN oder die Einstellung der Spannung verändert werden, bevor der vordere Geräteteil sich auf der höchsten Position am Turm befindet! Werden diese Anweisungen nicht befolgt, kann es zu schweren Verletzungen oder Geräteschäden kommen!

WAARSCHUWING: Gevaar - opgeslagen energie: Het liftmechanisme in de toren staat onder spanning en kan uit zichzelf snel omhoog bewegen, zodra de bevestigde apparatuur wordt verwijderd. Daarom dient u GEEN apparatuur te verwijderen of aanpassingen te doen aan de liftspanning, tenzij u het voorgedelde in de hoogste positie op de toren hebt geplaatst! Als u deze aanwijzingen niet opvolgt, kan dat leiden tot ernstig persoonlijk letsel en/of schade aan apparatuur!

AVVERTENZA: Rischio energia accumulata: Il meccanismo di sollevamento nella torre è sotto tensione e si muove rapidamente, automaticamente, non appena l'apparecchiatura collegata viene rimossa. Per questa ragione, NON rimuovere l'attrezzatura o apportare modifiche alla tensione del sollevamento a meno che il gruppo anteriore non sia stato spostato nel punto più alto della torre! La mancata osservanza di queste istruzioni potrebbe causare lesioni personali o danni alle apparecchiature!

警告: 蓄積エネルギーの危険性: タワーのリフト機構には張力がかかっており、付属していた器具が取り外された瞬間に高速で上に移動します。このため、前面の部品がタワーの最高位置にない場合は、器具を取り外したり、張力を調整して増加させないようにしてください。この指示に従わない場合、重篤な身体傷害おびまたは器具の破損の原因となります。

警告: 儲積エネルギーの危険性: タワーのリフト機構は張力がかかっており、付属していた器具が取り外された瞬間に高速で上に移動します。このため、前面の部品がタワーの最高位置にない場合は、器具を取り外したり、張力を調整して増加させないようにしてください。この指示に従わない場合、重篤な身体傷害おびまたは器具の破損の原因となります。

경고: 저장에너지 위험성: 타워의 리프트 기구장치는 장력을 받는 상태에 있으며, 광속 장비가 제거되거나 바로 자체의 빠른 속도로 올라가게 됩니다. 이러한 이유로, 장비 해체분리가 타워의 가장 높은 지점으로 올라가거나 또는 장력을 조절하지 마십시오! 이 안내를 따르지 않으면, 심각한 부상 및/또는 장기의 손상을 초래할 수 있습니다!