



### Highlights

- Constant Force (CF) patented motion technology produces smooth tilt adjustment—set display in position with just a light touch
- Position your LCD or TV for maximum comfort and productivity
- Fits VESA-compliant LCDs  $\leq 42"$  weighing up to 50 lbs (23 kg)
- Up to 20° of smooth continuous tilt adjustment (15° forward/5° back)
- Up to 360° of pan motion with the Swing Arm, 40° on the Pivot
- Allows display to be rotated for portrait or landscape viewing
- Compatible with multiple VESA hole mounting patterns: 75 x 75, 100 x 100, 100 x 200, 200 x 200 mm
- Tested to four times its maximum weight capacity as required by UL Standard 1678—do not exceed 50 lbs in actual use

## Ergotron® LX HD

### Wall Mount Pivot and Swing Arm



Ergotron's LX HD mounts offer a flexible alternative to rigid wall mounts for LCD displays or TVs weighing up to 50 lbs (23 kg). Embedded with Ergotron's patented CF technology, the LX HD Wall Mount enables effortless screen adjustment for optimal viewing comfort. These dependable solutions secure your flat panel investment while their sleek design elegantly complements home or office décor. LX HD mounts offer reliability, quality and design at a genuinely competitive price.

- Effortless adjustment for premium viewing
- Secure your display investment with a quality and reliable solution
- Aesthetics make it the perfect accessory for the home or office
- Swing Arm extends LCD out from the wall 13" (33 cm) for comfortable viewing
- Excellent price performance—most affordable wall mount solution for medium displays



Cables are guided along underside of arm

Patented CF pivot motion technology produces smooth tilt adjustment  
Screen's viewing angle is easily adjusted for each user

Sleek and strong—LX HDs have been tested to four times their maximum weight capacity as required by UL Standard 1678 (do not exceed 50 lbs in actual use)



Tilt lock-down feature also provides tilt tension for odd-sized displays that have an extremely forward center of gravity



**Simple 3-Step Install Process**

- ① Attach wall base to wall
- ② Attach mounting brackets to display
- ③ Hang display on wall plate



Swing Arm LCD Size	Weight Capacity	Lift	Tilt	Pan	Rotation	VESA
≤ 42"	≤ 50 lbs* ≤ 23 kg	—	20°	360°	360° P/L	MIS-D/E/F**

Pivot LCD Size	Weight Capacity	Lift	Tilt	Pan	Rotation	VESA
≤ 42"	≤ 50 lbs* ≤ 23 kg	—	20°	40°	360° P/L	MIS-D/E/F**

\* Display depth greater than 4" (10 cm) may diminish capacity.

\*\* VESA MIS-D, 75/100 (hole pattern = 100 x 100 mm & 75 x 75 mm), MIS-E (hole pattern = 200 x 100 mm), MIS-F (hole pattern = 200 x 200 mm ONLY). Optional VESA Bracket Adaptor Kit (97-474) can be ordered separately for MIS-F interface with hole pattern = 400 x 200 mm

LCD Size is approximation. Dimension is diagonal measurement of screen. LCD Size may be exceeded as long as screen weight does not exceed maximum weight capacity of the mount.

Product Name	LX HD Wall Mount Swing Arm 45-268-026 (polished aluminum)
Part Number	LX HD Wall Mount Pivot 45-269-009 (black)
Product Includes	Hardware for mounting to wood stud or concrete wall
Depth	3.7" (9,1 cm)
Shipping Dimensions	45-194-194: 12.5" x 7.75" x 4.5" (31,8 x 19,7 x 11,4 cm) 45-195-194: 9" x 9" x 3.9" (22,9 x 22,9 x 9,9 cm)
Shipping Weight	45-194-194: 5.5 lbs (2,5 kg) 45-195-194: 4.6 lbs (2,1 kg)
Warranty	3 years

© 2011 Ergotron, Inc. rev. 04/14/2011 e-05-106-EA Content is subject to change without notification

**Americas Sales and Corporate Headquarters**

St. Paul, MN USA  
(800) 888-8458  
+1-651-681-7600  
www.ergotron.com  
sales@ergotron.com

**EMEA Sales**

Amersfoort, The Netherlands  
+31 33 45 45 600  
www.ergotron.com  
info.eu@ergotron.com

**APAC Sales**

Tokyo, Japan  
www.ergotron.com  
apaccustomerservice@ergotron.com

**Worldwide OEM Sales**

www.ergotron.com  
info.oem@ergotron.com





## Highlights

- Position your keyboard for maximum comfort and productivity
- Arm extends keyboard up to 35" (89 cm); 13" (33 cm) height adjustment
- Ergonomic back-tilt keyboard tray ensures wrists remain in a neutral position during data entry—avoid repetitive-stress injuries while increasing comfort and productivity
- Creates a complete workstation when paired with the LX LCD Arm
- Easy to use—simple installation and effortless operation
- Mouse tray slides out to left or right, depending on user preference
- Ideal for space-constrained spaces—folds to within 3.5" (9 cm) of wall in storage position
- Integrated cable management
- Pair it with an LX LCD Arm to create a complete workstation
- Five-year warranty

# Ergotron®

## LX Wall Mount Keyboard Arm



### Durable polished aluminum construction!

Effortlessly position a keyboard to the most comfortable typing position, seated or standing. The LX Keyboard Arm mounts directly to any wall while providing vertical and side-to-side motion. When not in use, simply push the keyboard and fold it up to within 3.5" (9 cm) of the wall. This is the perfect accessory for space-constrained areas. Pair it with an LX LCD Arm to create a complete workstation.

Ergotron's LX Keyboard Arm includes Constant Force (CF) patented lift-and-pivot motion technology. With a light touch of your hand you can easily lift, swing, tilt or turn your keyboard.

- Increase data-entry comfort—help reduce arm, shoulder and wrist strain
- Reposition your keyboard with just a touch
- There when you need it, gone when you don't—folds up and back
- Excellent price performance
- Companion product to LX Wall Mount LCD Arm—same sleek design
- Arm extends keyboard up to 35" (89 cm)

- LX Keyboard Arm can be used without its extension
- Mounting options: attaches directly to sturdy vertical surfaces. Where applicable, install to wood stud. Also attaches to Wall Track using bracket 97-091 (order separately)
- Fasteners for direct attachment to wood/metal studs or concrete surface are not included—customer supplied
- Base includes theft deterrent anchor holes for cable locks



Keyboard Size	Keyboard Weight	Lift	Tilt	Pan	Rotation	VESA
see below	≤ 5 lbs ≤ 2,2 kg	13" 33 cm	80°	360°	—	—

Dimensions

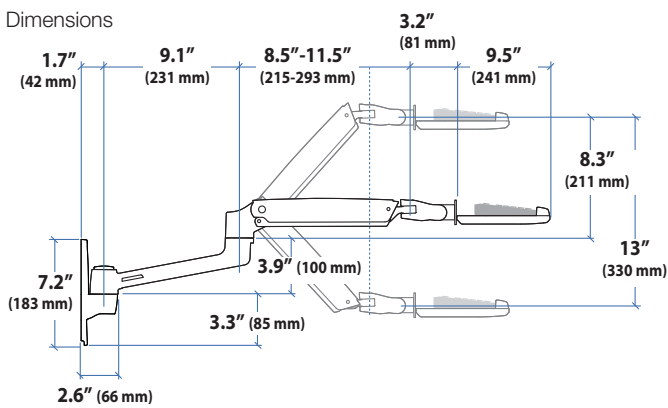

Product Name	LX Keyboard Arm
Part Number	45-246-026 (polished aluminum)
Product Includes	LX arm, extension, keyboard tray, mouse tray, wall mount base, mouse holder, wrist rest
Shipping Dimensions	20.75"H x 11.25"W x 7.5"D (53 x 29 x 19 cm)
Shipping Weight	9.7 lbs (4,4 kg)
Warranty	5 years
Weight Capacity	5 lbs (2,2 kg)
Keyboard Size	Maximum: 17.5" x 10.1" (44,5 x 25,7 cm)

© 2010 Ergotron, Inc. rev. 03/01/2010 e-05-068 Content is subject to change without notification.

**Americas Sales and Corporate Headquarters**

St. Paul, MN USA  
 (800) 888-8458  
 +1-651-681-7600  
 www.ergotron.com  
 sales@ergotron.com

**EMEA Sales**

Amersfoort, The Netherlands  
 +31 33 45 45 600  
 www.ergotron.com  
 info.eu@ergotron.com

**APAC Sales**

Tokyo, Japan  
 www.ergotron.com  
 apaccustomerservice@ergotron.com

**Worldwide OEM Sales**

www.ergotron.com  
 info.oem@ergotron.com

