

# FITUP

Universal table top TV mount



**ERARD®**

# FiTUP

Universal table top TV mount

Replaces the original base



Permits to place a sound bar  
under the screen

**2 Sizes** adaptable to all screens from 20" to 65"



FiTUP XL



FiTUP L

# FiTUP L

Ref. **035300**

EAN 318528 035300 2

- Adaptable to all screens from 20" to 50"
- Screen height adjustment
- Maximum load : 20 kg
- Steel, 5 mm thick
- Silver and black epoxy painting

**L** **20"-50"**  
51-127 cm

MAXI : 20 KG / THICKNESS 50MM

 VESA L50... x H50→400

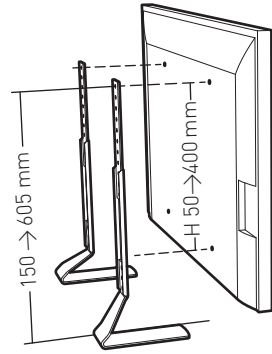

# FiTUP XL

Ref. **035310**

EAN 318528 035310 1

- Adaptable to all screens from 40" to 65"
- Screen height adjustment
- Maximum load : 30 kg
- Steel, 5 mm thick
- Silver and black epoxy painting

**XL** **40"-65"**  
102-165 cm

MAXI : 30 KG / THICKNESS 50MM

 VESA L100... x H100→600

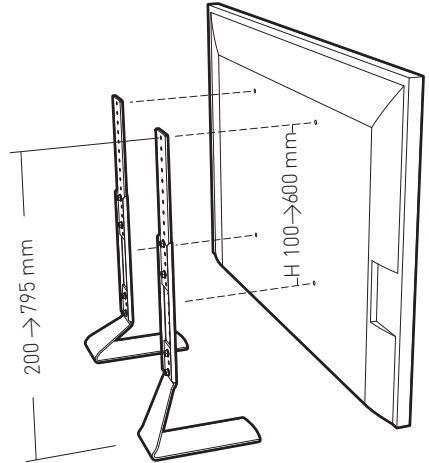

OPTION

**KIT TV ADAPT+**  
REF : 049592

Adaptation kit for screens  
with uneven back panel

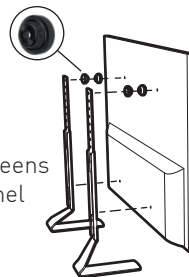

10 YEARS GUARANTEE



BVCert. 6164725



**Catalogues Supports et Meubles pour écrans plats**

Mounts and furniture for flat screens Catalogue  
 Katalog Halterungen und Möbel für Flachbildschirme



**Catalogue Systèmes de fixations pour antennes et paraboles**

Mounting systems for antennas and satellite dishes Catalogue  
 Katalog Befestigungssysteme für Antennen und Satellitenschüsseln



**Catalogue Systèmes de Connexion Grand Public et Professionnels**

Connection systems catalogue  
 Katalog für Anschluss-Systeme



**Catalogue ERARD Pro**

ERARD Pro Catalogue  
 Katalog Erard Pro

**ERARD**®  
 ESSENTIAL ACCESSORIES  
 FOR AUDIO VIDEO COMPONENTS

Mail : [export@erard.fr](mailto:export@erard.fr) / [www.erard.com](http://www.erard.com) / Tel : +33 (0)4 72 46 16 26 / Fax : +33 (0)4 72 46 16 22

VAT N°: FR 81 403 591 415

Z.I. de Chavanoz / 4 route de la Plaine / 38230 CHAVANOZ / FRANCE

