



Communicative. Prestigious. Interactive.

TABLET HOLDER FLOOR

Exquisitely designed with optimal functionality, TABLET HOLDER FLOOR is a perfect presentation tool. Premium-quality design, optimal stability and individual adjustment facilities support the attractive presentation of products, information materials and services.

In combination with its flexible tilt angle adjustment, this tablet holder system can be used as a multi-functional communication platform at events such as trade fairs and conferences, at info points and at the point of sale.

A multiple anti-theft protection system ensures a high level of security for the tablet and the floor stand.

- › For all tablet formats from 7" – 13"
- › Integrated cable management
- › Rotatable by 360°, can be used in portrait or landscape format
- › Flexible tilt angle adjustment
- › Multiple anti-theft protection

8932-23

FUNCTION AND TECHNOLOGY

- › Variable fit for all tablet sizes from 7" to 13"
- › Symmetrical opening of the holder: Dynamic opening dimensions from 160 to 275 mm
- › Easy insertion and removal of the tablet
- › Rotatable: 360° for portrait and landscape format – with snap-in points at every 90°
- › Tablet load capacity: max. 1,000 g
- › Anti-theft protection by inserting the dust-free adhesive strip
- › Effective protection against lateral removal of the tablet PC
- › Locking of the holder with a special key
- › Cable management: Aperture in the holder serves as charging cable outlet for the tablet

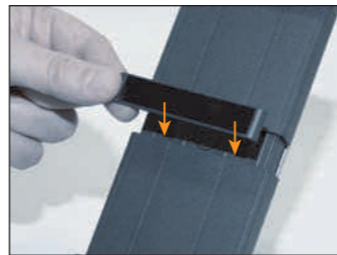

TABLET HOLDER WALL

- › Materials: Aluminium, ABS
- › Dimensions: 85 x 50 x 180 mm (W x H x D)
- › Weight: 340 g
- › Product # 8933-23

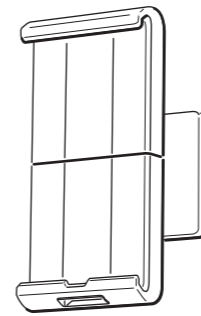

TABLET HOLDER TABLE

- › Flexible tilt angle adjustment of the arm: 0° to 88°
- › Additional anti-theft protection via cable lock
- › Materials: Sheet steel, aluminium, ABS
- › Dimensions: 155 x 242 x 183 mm (W x H x D)
- › Weight: 1,150 g
- › Product # 8930-23

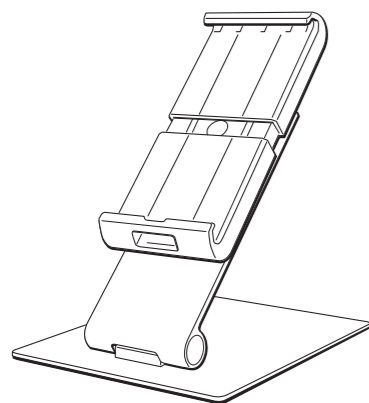

TABLET HOLDER TABLE is fitted with a locking slot for anti-theft protection, for insertion of a MiniSaver™ cable lock from Kensington®. The cable lock is not included in the delivery. Kensington® is a registered trade mark of the ACCO BRANDS CORPORATION, 60047-8997, Lake Zurich, US.



TABLET HOLDER WALL ARM

- › Tilt angle range of holder: -6° to +46°; rotatable: 170°
- › Arm radius: 365 mm; swivel range: 180°
- › Materials: Sheet steel, aluminium, ABS
- › Dimensions: 95 x 225 x 170 mm (W x H x D)
- › Weight: 650 g
- › Product # 8934-23

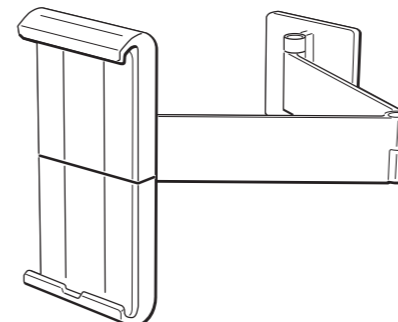

TABLET HOLDER TABLE CLAMP

- › Height of table column: 295 mm
- › Tilt angle range of holder: -6° to +46°; rotatable: 170°
- › Arm radius: 365 mm; swivel range: 180°
- › Clamping width of table clamp: for up to 40 mm table top thickness
- › Materials: Aluminium, ABS
- › Dimensions: 100 x 440 x 210 mm (W x H x D)
- › Weight: 1,050 g
- › Product # 8931-23

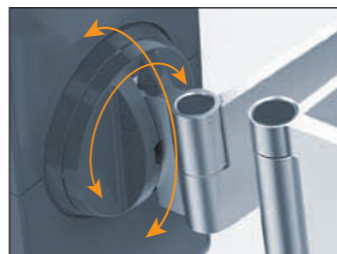
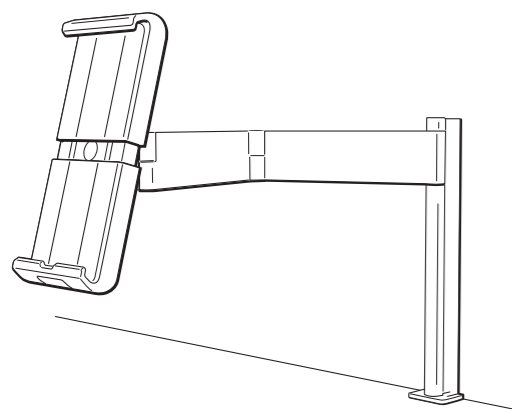

TABLET HOLDER FLOOR

- › Flexible tilt angle adjustment: 0° to 88°
- › Additional anti-theft protection via cable lock
- › Materials: Sheet steel, aluminium, ABS
- › Dimensions: 270 x 1215 x 270 mm (W x H x D)
- › Weight: 5,100 g
- › Cable conduit with cable manager, adjustable across the entire height range
- › USB connection cable included in the delivery
- › Product # 8932-23

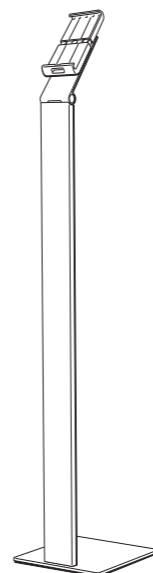

TABLET HOLDER FLOOR comes with a standardised locking slot for insertion of a cable lock for anti-theft protection. The notebook cable lock shown in the picture is not included in the delivery.

