

Ergotron® LX

HD Sit-Stand Wall Mount LCD Arm

Dimensional &
Range of Motion
Illustrations

Dimensions

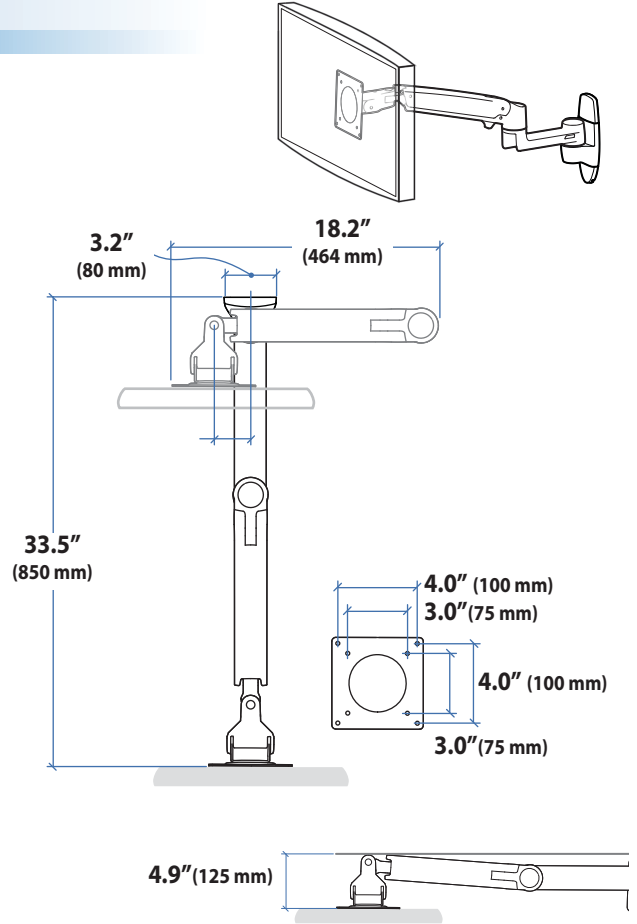
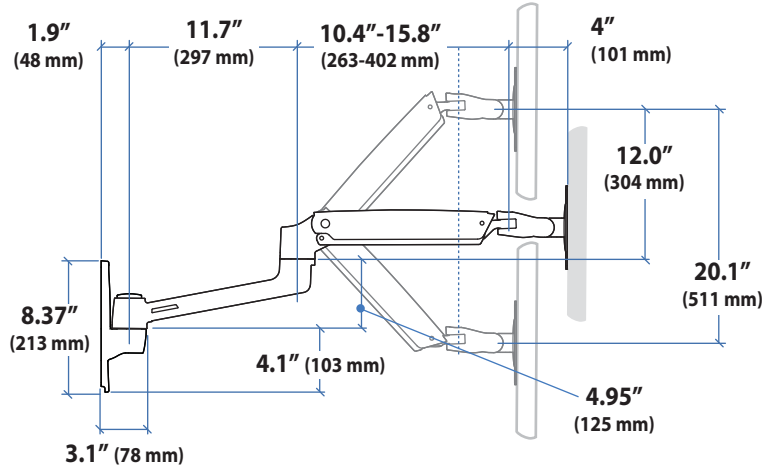

Wall Mount Bracket

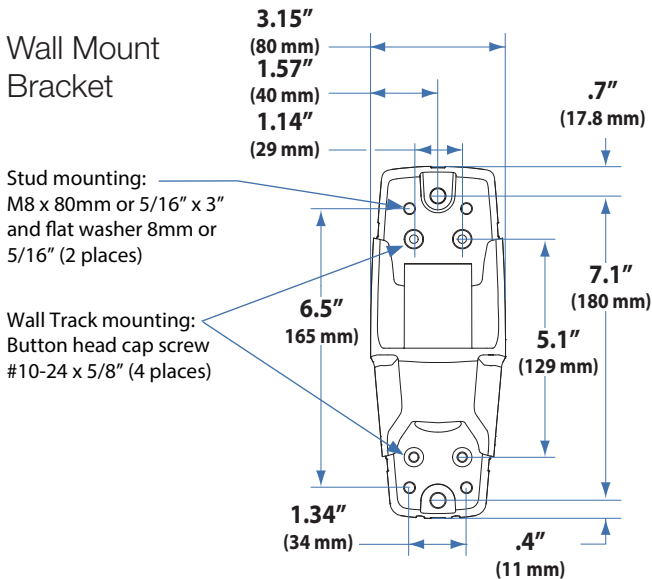

Front view with arm pushed back against the wall.

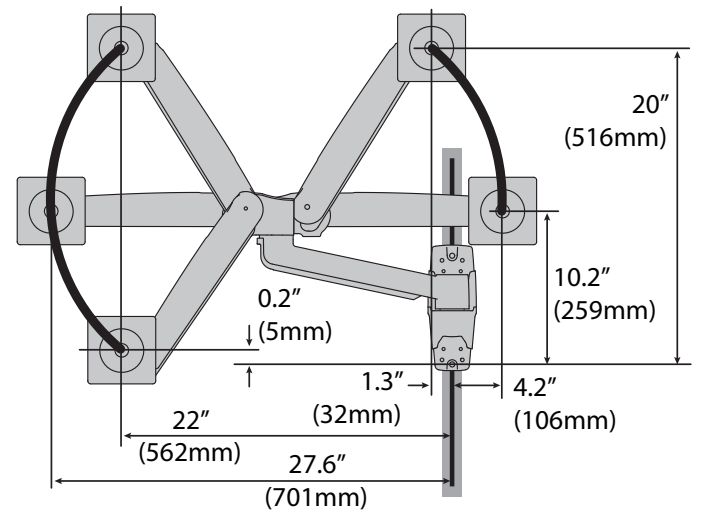

© 2013 Ergotron, Inc. rev. 11/14/2013 DIM-LXHDStWall Content is subject to change without notification

Americas Sales and Corporate Headquarters

St. Paul, MN USA
(800) 888-8458
+1-651-681-7600
www.ergotron.com
sales@ergotron.com

EMEA Sales

Amersfoort, The Netherlands
+31 33 45 45 600
www.ergotron.com
info.eu@ergotron.com

APAC Sale

Tokyo, Japan
www.ergotron.com
apaccustomerservice@ergotron.com

Worldwide OEM Sales

www.ergotron.com
info.oem@ergotron.com



Ergotron® LX

HD Sit-Stand Wall Mount LCD Arm

Dimensional &
Range of Motion
Illustrations

Weight Capacity

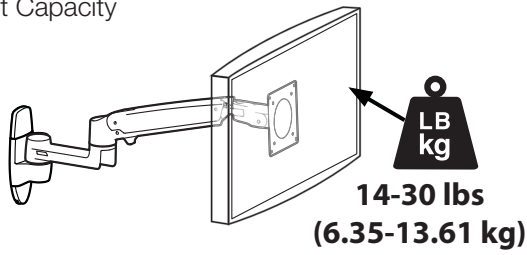

**Maximum Screen
Size = 46"
Limited to 30 lbs
maximum**

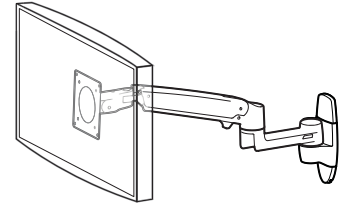

Monitor depth greater than 2.5" (64 mm) may diminish capacity.
Call Ergotron for more information.

Range of Motion

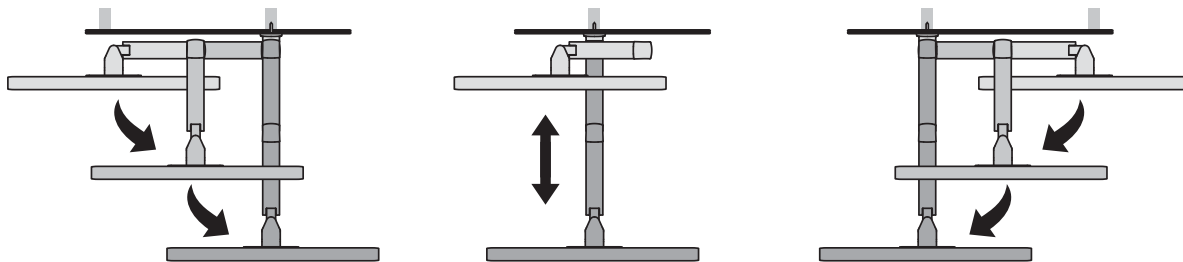
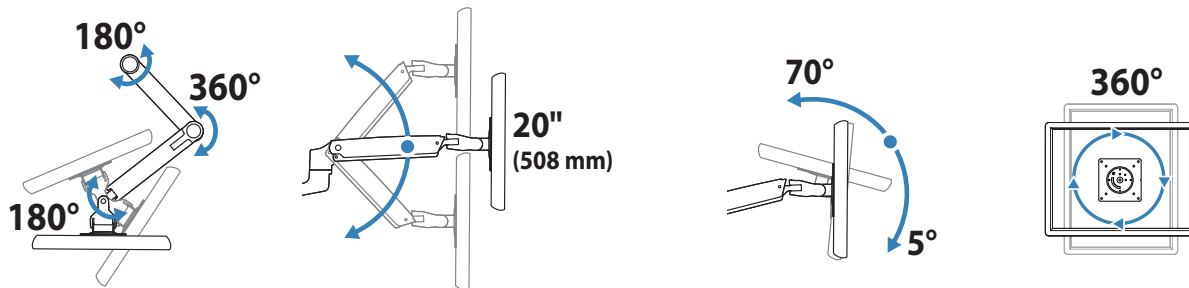

© 2013 Ergotron, Inc. rev. 11/14/2013 DIM-LXHDStWall Content is subject to change without notification

Americas Sales and Corporate Headquarters

St. Paul, MN USA
(800) 888-8458
+1-651-681-7600
www.ergotron.com
sales@ergotron.com

EMEA Sales

Amersfoort, The Netherlands
+31 33 45 45 600
www.ergotron.com
info.eu@ergotron.com

APAC Sale

Tokyo, Japan
www.ergotron.com
apaccustomerservice@ergotron.com

Worldwide OEM Sales

www.ergotron.com
info.oem@ergotron.com



Dual Monitor and Handle Kit

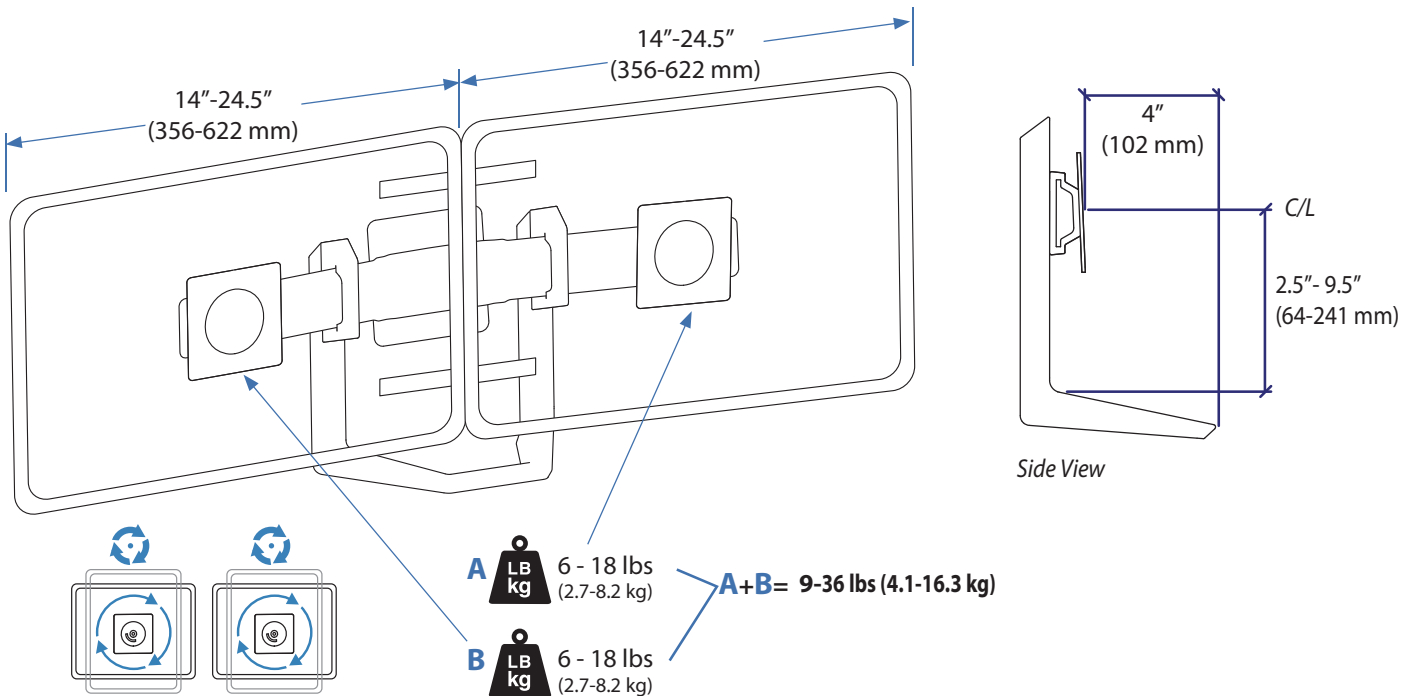

This product adds an additional 6 lbs (2.7 kg) to your mounting solution. Your mounting solution's monitor weight capacity must be reduced by 6 lbs (2.7 kg) when using standard monitors less than or equal to 2.5" (64 mm) thick. Additional reduction will be required if monitors are greater than 2.5" (64 mm) thick.

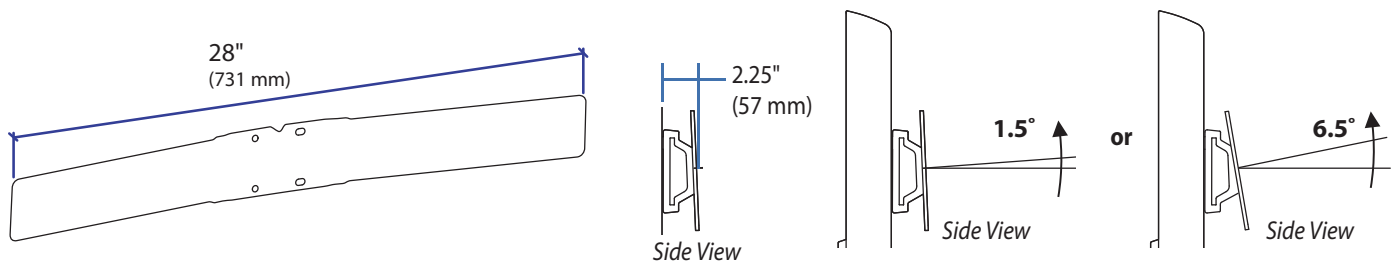

There are 2 ways to mount this product based on what mounting solution you are attaching this product to.

1. Attaching this product to a mounting solution with 100 x 100 mm mounting hole pattern.
2. Attaching this product to a mounting solution with a 50 x 50 mm mounting hole pattern.

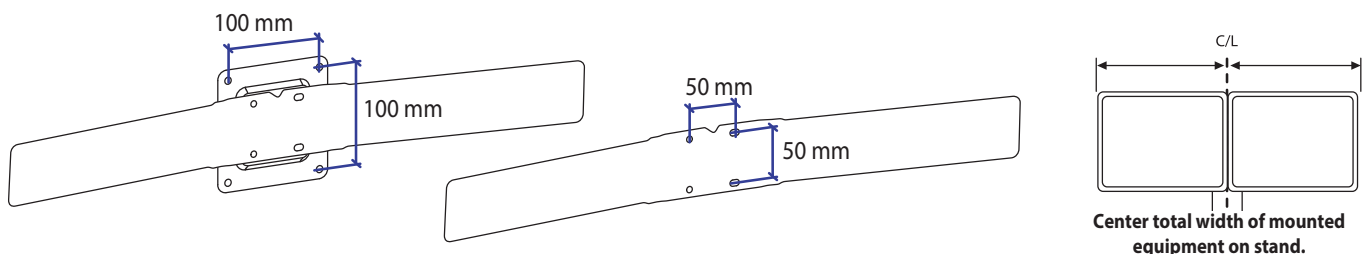

© 2013 Ergotron, Inc. rev. 06/27/2013 DIM-DualBowHandle Content is subject to change without notification

Americas Sales and Corporate Headquarters

St. Paul, MN USA
 (800) 888-8458
 +1-651-681-7600
 www.ergotron.com
 sales@ergotron.com

EMEA Sales

Amersfoort, The Netherlands
 +31 33 45 45 600
 www.ergotron.com
 info.eu@ergotron.com

APAC Sales

Tokyo, Japan
 www.ergotron.com
 apaccustomerservice@ergotron.com

Worldwide OEM Sales

www.ergotron.com
 info.oem@ergotron.com

